

N1092A/B/C/D/E DCA-M

Optical and Electrical Sampling Oscilloscopes

High accuracy, low cost solutions for optical and electrical waveform analysis.

- Solutions for 20 Gb/s through 53 GBaud
- Very low noise and jitter
- Fast sampling rates for high throughput



Table of Contents

Legendary DCA Accuracy	3
Small Form Factor Ideal for Both Manufacturing and R&D Applications	3
Controlling the N1092A/B/C/D/E	4
Connection Schemes	4
System setup	5
Module SIRC Filters	6
N1092A/B/C/D/E Specifications	7
N1092A/B/C/D/E (Option 30A) Optical Channel Specifications	7
N1092A/B/C/D/E (Option 40A) Optical Channel Specifications without Option CDR	9
N1092A/B (Option 40A) Optical Channel Specifications with Option CDR	10
N1092C/E Electrical Channel Specifications	12
N1092A/B/C/D/E Horizontal Timebase Specifications	13
N1092A/B/C/D/E Clock Input Specifications	13
N1092A/B (Option 40A) Clock Recovery Specifications with Option CDR	14
N1092A/B/C/D/E Environmental Specifications	15
Ordering Information – N1092A/B/C/D/E	16

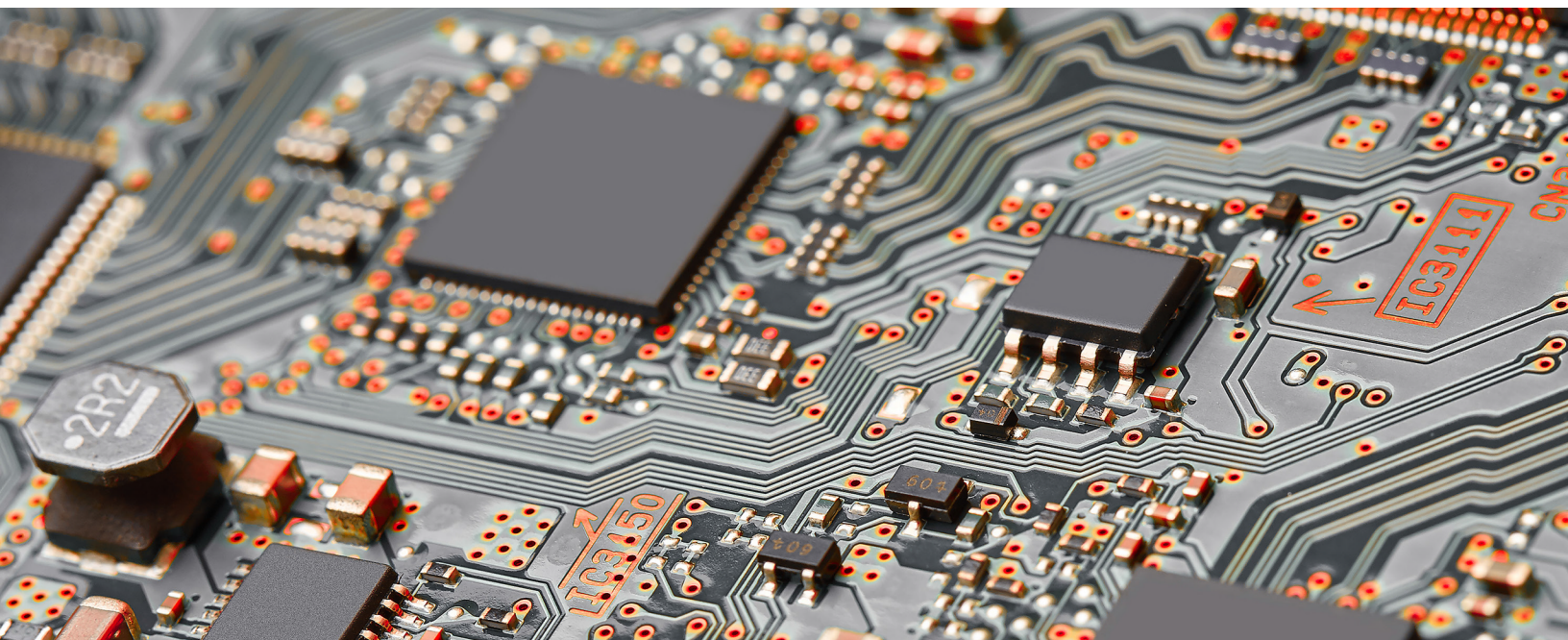

Legendary DCA Accuracy

The Keysight Technologies, Inc. N1000 and 86100 digital communication analyzer (DCA) family is recognized as the industry standard for verifying optical transmitter compliance to communications standards. For years engineers have trusted the DCA to provide accurate and easy measurement of digital communication waveforms. The Keysight N1092A/B/C/D/E DCA-M has built on that legacy by using the high-performance elements of both the N1000 and 86100 oscilloscope mainframe acquisition system and the optical and electrical channel hardware of the 861XX and N104X plug-in modules.

Small Form Factor Ideal for Both Manufacturing and R&D Applications

Unlike the 86100D and N1000A, which use modules to create a waveform analysis system, the N109X are completely integrated instruments built in a small form factor. Low noise, high-sensitivity calibrated optical reference receivers – compliant to industry standard tolerances – are available for both multimode and single-mode, creating a measurement system with very high dynamic range. Electrical channels are available with 30 GHz and 50 GHz bandwidths.



User Interface

The N109X user interface and operating system is identical to the modern FlexDCA interface of the 86100D and N1000A. A user-provided PC running N1010A FlexDCA software controls the N1092A/B/C/D/E over a simple USB 2.0 or 3.0 connection.



Controlling the N1092A/B/C/D/E

There are three ways to control the N109X system

- A PC directly connected to the N1092A/B/C/D/E with a USB cable
- An 86100D or N1000A mainframe connected to the N1092A/B/C/D/E with a USB cable. (The mainframe can then be controlled via GPIB or LAN)
- For an automated test system environment, the simplest and preferred method to control the N1092A/B/C/D/E is to connect the primary test system PC to a low-cost modern PC via LAN. The FlexDCA interface resides on the second PC. The second PC is then connected to the N1092A/B/C/D/E via USB. This eliminates most issues of compatibility between an existing test system PC and the N1092A/B/C/D/E hardware and can greatly simplify converting an 86100D system to an N1092A/B/C/D/E system

Connection Schemes

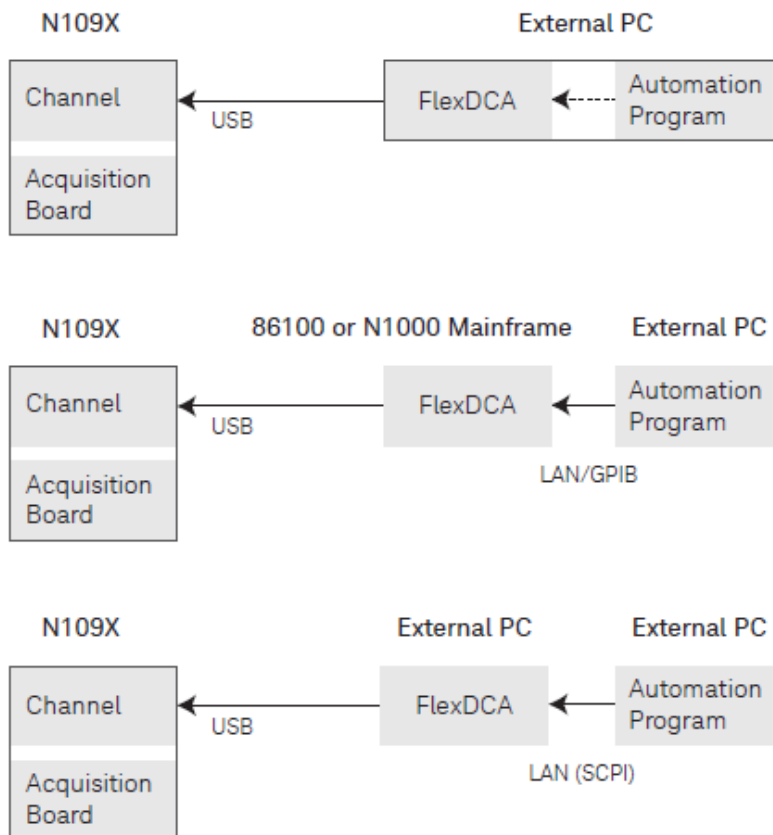

Figure 1. Connection Schemes

System setup

The following guidelines indicate the fundamental requirements for PC's connected to the N109X and running the FlexDCA interface:

For a single channel setup

- Intel I3 processor or better
- 4 GB memory
- Windows 7 (32 or 64 bit)

For a parallel test setup (multiple instruments or multiple channels)

- Intel I5 or better
- 8 GB memory
- Windows 7 (64 bit)

The communication API between your system controller and the PC is SCPI over LAN, either VXI-11 or HiSlip. If NI-VISA or IO Libraries are used to communicate with GPIB instruments, the switch to SCPI/LAN is very simple. It is important to note that there is no need to do any USB programming. This is all handled by the FlexDCA interface.

The FlexDCA interface is free and can be downloaded at www.keysight.com/find/flexdca_download. Remote programs previously developed using the 86100 or N1000 FlexDCA interface can be leveraged directly to control an automated N1092A/B/C/D/E system. Use FlexDCA SCPI programming tools to simplify conversion of legacy 86100-based automation to FlexDCA compatible code. Measurement results are generally faster with the new N1092A/B/C/D/E due to significantly faster sampling rates.

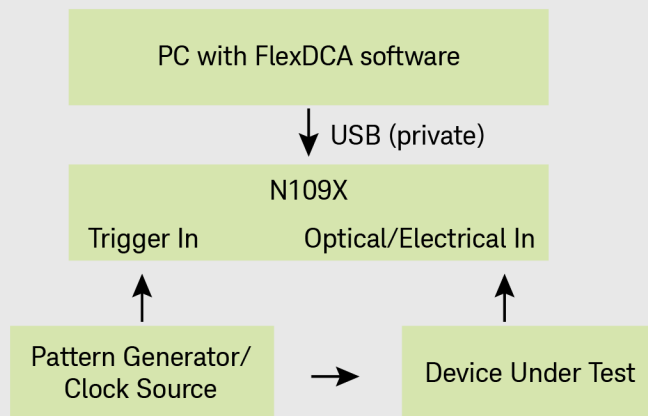

Figure 2. N1090X Test Setup

Similar to the 86100 and N1000, a reference clock, synchronous with the signal being measured, is required to trigger the N109X. Timebase calibration, previously performed at service centers, can now be performed by users, reducing cost of ownership and instrument down time.

Module SIRC Filters

System Impulse Response Correction (SIRC) filters provide channel SIRC measurement and data files to give an ideal channel response. SIRC data can be applied in FlexDCA's System Impulse Response Correction dialog. The SIRC correction data feature is a digital filter that is used to:

- Improve the response of module reference filters to more closely match an ideal receiver.
- Enable non-standard reference receiver rates or bandwidths.
- Increase the bandwidth of the channel by up to 50%.
- Ensures that an eye diagram will look identical between different modules.

SIRC correction data is unique to a specific N1092A/B/C/D/E serial number. The data can be purchased with new modules or purchased as an upgrade for your existing modules. Purchasing data for an existing module requires that the module be returned to Keysight Technologies. To order SIRC data, contact your Keysight representative or visit <http://www.keysight.com/Find/FlexDCA>.

N1092-Series SIRC Filter Ranges*

Module/Option	Channel	Min SIRC Freq.	Max SIRC Freq.
N1092x Option 30A	All Optical	12.89 GBd (9.67 GHz)	53.125 GBd (39.8 GHz)
N1092x Option 40A	All Optical	12.89 GBd (9.67 GHz)	64 GBd (48 GHz)
N1092x Options 30A <i>and</i> 168	All Optical	8.4 GBd (6.3 GHz)	53.125 GBd (39.8 GHz)

* Only available with option IRC and compliance not guaranteed.

N1092A/B/C/D/E Specifications

N1092A/B/C/D/E (Option 30A) Optical Channel Specifications

Item	Description		
Optical Channel Count	1 (N1092A/C) 2 (N1092B/E) 4 (N1092D)		
Optical Channel Bandwidth, -3 dB	28 GHz(characteristic) ¹		
Nominal Wavelength Range	830 nm to 1600 nm		
Factory calibrated wavelengths ²	850 nm (±20 nm) 1310 nm (±20 nm) 1550 nm (±20 nm)		
User calibration wavelength range	830 nm to 1600 nm		
RMS Noise (Characteristic)	850 nm	1310 nm	1550 nm
100GBASE-SR4 TDEC (12.6 GHz filter)	5 µW	3 µW	3.5 µW
20.625 Gb/s	7 µW	5 µW	5 µW
25 Gb/s Ethernet (25.78125 Gb/s)	8 µW	5.5 µW	5.5 µW
400GBASE-SR16 (26.5625 Gb/s)	8 µW	5.5 µW	5.5 µW
Ethernet OTU4 FEC/ITU-T G.959.1 (27.952493 Gb/s)	9.5 µW	6 µW	6 µW
32G Fibre Channel (28.05 Gb/s)	9.5 µW	6 µW	6 µW
RMS Noise (Maximum)	850 nm	1310 nm	1550 nm
100GBASE-SR4 TDEC (12.6 GHz filter)	7 µW	5 µW	5.5 µW
20.625 Gb/s	9 µW	7 µW	7.5 µW
25 Gb/s Ethernet (25.78125 Gb/s)	10 µW	7 µW	7.5 µW
400GBASE-SR16 (26.5625 Gb/s)	10 µW	7 µW	7.5 µW
Ethernet OTU4 FEC/ITU-T G.959.1 (27.952493 Gb/s)	11 µW	8 µW	8.5 µW
32G Fibre Channel (28.05 Gb/s)	11 µW	8 µW	8.5 µW
Optical Sensitivity (Characteristic) ³	850 nm	1310 nm	1550 nm
20.625 Gb/s	-11.5 dBm	-13.0 dBm	-13.0 dBm
25 Gb/s Ethernet (25.78125 Gb/s)	-11 dBm	-12.5 dBm	-12.5 dBm
400GBASE-SR16 (26.5625 Gb/s)	-11 dBm	-12.5 dBm	-12.5 dBm
Ethernet OTU4 FEC/ITU-T G.959.1 (27.952493 Gb/s)	-10 dBm	-12 dBm	-12 dBm
32G Fibre Channel (28.05 Gb/s)	-10 dBm	-12 dBm	-12 dBm
Scale Factor Specifications (per division, 8 divisions)			
Minimum	5 µW		
Maximum	500 µW		
CW Offset Range ⁴	+1.0 mW to -3 mW		
CW Accuracy ⁵			
Single-Mode	±15 µW ±1.5% of reading ± connector uncertainty (Characteristic) ±30 µW ±3% of reading ± connector uncertainty		
Multimode	±25 µW ±10% of reading ± connector uncertainty (Characteristic)		
Maximum Measureable Input Power			
100GBASE-SR4 TDEC (12.6 GHz filter) ⁶	4 mW at 500 µW/division scale factor (Characteristic) 3 mW at 500 µW/division scale factor		
20.625 Gb/s	4 mW at 500 µW/division scale factor		

25 Gb/s Ethernet (25.78125 Gb/s)	4 mW at 500 μ W/division scale factor
400GBASE-SR16 (26.5625 Gb/s)	4 mW at 500 μ W/division scale factor
Ethernet OTU4 FEC/ITU-T G.959.1 (27.952493 Gb/s)	4 mW at 500 μ W/division scale factor
32G Fibre Channel (28.05 Gb/s)	4 mW at 500 μ W/division scale factor
Average Power Monitor Range	-30 dBm to 0 dBm (850 nm) -30 dBm to +6 dBm (1310 nm) -30 dBm to +6 dBm (1550 nm)
Average Power Monitor Accuracy ^{7, 8}	
Single-Mode	200 nW \pm 5% of reading \pm connector uncertainty
Multimode	200 nW \pm 10% of reading \pm connector uncertainty (Characteristic)
Maximum Non-destruct Peak Power	8 mW (+9 dBm)
Fiber Input ⁹	50/125 μ m
Fiber Input Connector	FC
Channel ADC	16 bits

¹ With the 32G Fibre Channel reference receiver filter selected, -3 dBo is calculated from the -6 dBc point.

² For the average power monitor and the channel vertical path.

³ Generally represents the power level where an ideal eye diagram will approach 0% mask margin due to the noise of the oscilloscope. Provides a *non-specified* figure of merit to compare sensitivities of various optical channels. These values are calculated from the characteristic noise values.

⁴ Referenced two divisions from screen bottom.

⁵ Single marker, referenced to power sensor.

⁶ When a TDEC filter is used any portion of the signal that is displayed above 3 mW is not warranted.

⁷ Due to variations in mode-filling conditions, the measured power in multimode fiber will vary more than the measured power in single-mode fiber. For users needing the most accurate power measurements, use an optical power meter for multimode power measurements.

⁸ Average power monitor accuracy is tied to the calibration accuracy of the power sensor.

⁹ Compatible with external fibers with <50 μ m cores.

N1092A/B/C/D/E (Option 40A) Optical Channel Specifications without Option CDR

Item	Description	
Optical Channel Count	1 (N1092A/C) 2 (N1092B/E) 4 (N1092D)	
Optical Channel Bandwidth, -3 dBo	45 GHz (characteristic) ¹	
Nominal Wavelength Range	1250 nm to 1600 nm	
Factory calibrated wavelengths ²	1310 nm (±20 nm) 1550 nm (±20 nm)	
User calibration wavelength range	1250 nm to 1600 nm	
RMS Noise (Characteristic)	1310 nm	1550 nm
25 Gb/s Ethernet (25.78125 Gb/s)	5.5 µW	6.5 µW
400GBASE-SR16 (26.5625 Gb/s)	5.5 µW	6.5 µW
Ethernet OTU4 FEC/ITU-T G.959.1 (27.952493 Gb/s)	6 µW	6.5 µW
32G Fibre Channel (28.05 Gb/s)	6 µW	6.5 µW
53.125 GBaud PAM4 TDECQ (26.6 GHz)	6 µW	7.0 µW
Unfiltered	11 µW	14 µW
RMS Noise (Maximum)	1310 nm	1550 nm
25 Gb/s Ethernet (25.78125 Gb/s)	7 µW	7.5 µW
400GBASE-SR16 (26.5625 Gb/s)	7 µW	7.5 µW
Ethernet OTU4 FEC/ITU-T G.959.1 (27.952493 Gb/s)	8 µW	8.5 µW
32G Fibre Channel (28.05 Gb/s)	8 µW	8.5 µW
53.125 GBaud PAM4 TDECQ (26.6 GHz)	9 µW	9.5 µW
Unfiltered	14 µW	17 µW
Optical Sensitivity (Characteristic) ³	1310 nm	1550 nm
25 Gb/s Ethernet (25.78125 Gb/s)	-12.5 dBm	-12.5 dBm
400GBASE-SR16 (26.5625 Gb/s)	-12.5 dBm	-12.5 dBm
Ethernet OTU4 FEC/ITU-T G.959.1 (27.952493 Gb/s)	-12 dBm	-12 dBm
32G Fibre Channel (28.05 Gb/s)	-12 dBm	-12 dBm
Scale Factor Specifications (per division, 8 divisions)		
Minimum	5 µW	
Maximum	500 µW	
CW Offset Range ⁴	+1.0 mW to -3 mW	
CW Accuracy (single mode) ⁵	±15 µW ±1.5% of reading ± connector uncertainty (Characteristic) ±30 µW ±3% of reading ± connector uncertainty	
Maximum Measureable Input Power		
25 Gb/s Ethernet (25.78125 Gb/s)	4 mW at 500 µW/division scale factor	
400GBASE-SR16 (26.5625 Gb/s)	4 mW at 500 µW/division scale factor	
Ethernet OTU4 FEC/ITU-T G.959.1 (27.952493 Gb/s)	4 mW at 500 µW/division scale factor	
32G Fibre Channel (28.05 Gb/s)	4 mW at 500 µW/division scale factor	
53.125 GBaud PAM4 TDECQ (26.6 GHz)	4 mW at 500 µW/division scale factor	
Unfiltered	4 mW at 500 µW/division scale factor	
Average Power Monitor Range	-30 dBm to +6 dBm (1310 nm) -30 dBm to +6 dBm (1550 nm)	
Average Power Monitor Accuracy ⁶		
For 0 mW ≤ P _{input} ≤ 2 mW	200 nW ± 5% of reading ± connector uncertainty	

For $2 \text{ mW} \leq P_{\text{input}} \leq 4 \text{ mW}$	$200 \text{ nW} \pm 10\% \text{ of reading} - 100\mu\text{W} \pm \text{connector uncertainty}$
Maximum Non-destruct Peak Power	5 mW (+7 dBm)
Fiber Input	9/125 μm
Fiber Input Connector	FC
Channel ADC	16 bits

¹ With the unfiltered setting selected, -3 dBo is calculated from the -6 dBe point.

² For the average power monitor and the channel vertical path.

³ Generally represents the power level where an ideal eye diagram will approach 0% mask margin due to the noise of the oscilloscope. Provides a *non-specified* figure of merit to compare sensitivities of various optical channels. These values are calculated from the characteristic noise values.

⁴ Referenced two divisions from screen bottom.

⁵ Single marker, referenced to power sensor.

⁶ Average power monitor accuracy is tied to the calibration accuracy of the power sensor.

N1092A/B (Option 40A) Optical Channel Specifications with Option CDR

Item	Description	
Optical Channel Count	1 (N1092A) 2 (N1092B)	
Optical Channel Bandwidth, -3 dBo	45 GHz (characteristic) ¹	
Nominal Wavelength Range	1250 nm to 1600 nm	
Factory calibrated wavelengths ²	1310 nm (± 20 nm) 1550 nm (± 20 nm)	
User calibration wavelength range	1250 nm to 1600 nm	
RMS Noise (Characteristic)	1310 nm	1550 nm
25 Gb/s Ethernet (25.78125 Gb/s)	6.5 μW	7 μW
400GBASE-SR16 (26.5625 Gb/s)	6.5 μW	7 μW
Ethernet OTU4 FEC/ITU-T G.959.1 (27.952493 Gb/s)	6.5 μW	7 μW
32G Fibre Channel (28.05 Gb/s)	6.5 μW	7 μW
53.125 GBaud PAM4 TDECQ (26.6 GHz)	7.5 μW	8 μW
Unfiltered	17 μW	17.5 μW
RMS Noise (Maximum)	1310 nm	1550 nm
25 Gb/s Ethernet (25.78125 Gb/s)	9 μW	9.5 μW
400GBASE-SR16 (26.5625 Gb/s)	9 μW	9.5 μW
Ethernet OTU4 FEC/ITU-T G.959.1 (27.952493 Gb/s)	9 μW	9.5 μW
32G Fibre Channel (28.05 Gb/s)	9 μW	9.5 μW
53.125 GBaud PAM4 TDECQ (26.6 GHz)	9.5 μW	10 μW
Unfiltered	22 μW	22.5 μW
Optical Sensitivity (Characteristic) ³	1310 nm	1550 nm
25 Gb/s Ethernet (25.78125 Gb/s)	-11.5 dBm	-11.0 dBm
400GBASE-SR16 (26.5625 Gb/s)	-11.5 dBm	-11.0 dBm
Ethernet OTU4 FEC/ITU-T G.959.1 (27.952493 Gb/s)	-11.5 dBm	-11.0 dBm
32G Fibre Channel (28.05 Gb/s)	-11.5 dBm	-11.0 dBm
Scale Factor Specifications (per division, 8 divisions)		
Minimum	5 μW	
Maximum	500 μW	
CW Offset Range ⁴	+1.0 mW to -3 mW	
CW Accuracy (single mode) ⁵	$\pm 15 \mu\text{W} \pm 1.5\% \text{ of reading} \pm \text{connector uncertainty (Characteristic)}$ $\pm 30 \mu\text{W} \pm 3\% \text{ of reading} \pm \text{connector uncertainty}$	

Maximum Measureable Input Power	
25 Gb/s Ethernet (25.78125 Gb/s)	4 mW at 500 μ W/division scale factor
400GBASE-SR16 (26.5625 Gb/s)	4 mW at 500 μ W/division scale factor
Ethernet OTU4 FEC/ITU-T G.959.1 (27.952493 Gb/s)	4 mW at 500 μ W/division scale factor
32G Fibre Channel (28.05 Gb/s)	4 mW at 500 μ W/division scale factor
53.125 GBaud PAM4 TDECQ (26.6 GHz)	4 mW at 500 μ W/division scale factor
Unfiltered	4 mW at 500 μ W/division scale factor
Average Power Monitor Range	-30 dBm to +6 dBm (1310 nm) -30 dBm to +6 dBm (1550 nm)
Average Power Monitor Accuracy ⁶	
For $0 \text{ mW} \leq P_{\text{input}} \leq 2 \text{ mW}$	200 nW \pm 5% of reading \pm connector uncertainty
For $2 \text{ mW} \leq P_{\text{input}} \leq 4 \text{ mW}$	200 nW \pm 10% of reading - 100 μ W \pm connector uncertainty
Maximum Non-destruct Peak Power	5 mW (+7 dBm)
Fiber Input	9/125 μ m
Fiber Input Connector	FC
Channel ADC	16 bits

¹ With the unfiltered setting selected, -3 dBo is calculated from the -6 dBe point.

² For the average power monitor and the channel vertical path.

³ Generally represents the power level where an ideal eye diagram will approach 0% mask margin due to the noise of the oscilloscope. Provides a *non-specified* figure of merit to compare sensitivities of various optical channels. These values are calculated from the characteristic noise values.

⁴ Referenced two divisions from screen bottom.

⁵ Single marker, referenced to power sensor.

⁶ Average power monitor accuracy is tied to the calibration accuracy of the power sensor.

N1092C/E Electrical Channel Specifications

Item	Description
Electrical Channel Count	2 (N1092C/E)
Electrical Input Connectors	2.4 mm (m) bulkhead
Bandwidth, -3 dB (user selectable)	20, 33, 40, and 50 GHz ¹
Transition Time (10% to 90% calculated from TR = 0.35/BW)	
20 GHz BW	17.5 ps (Calculated)
33 GHz BW	10.6 ps (Calculated)
40 GHz BW	8.8 ps (Calculated)
50 GHz BW	7.0 ps (Calculated)
Channel-to-Channel Skew Range	±100 ps
RMS Noise	
20 GHz BW	275 μV (Characteristic)
33 GHz BW	420 μV (Characteristic)
40 GHz BW	450 μV (Characteristic)
50 GHz BW	500 μV (Characteristic)
RMS Noise (Maximum)	700 μV
Scale Factor (per division)	
Minimum	1 mV/division
Maximum	100 mV/division
DC Accuracy (V _{AVG} Measurement)	±2 mV ±4% (reading – offset) ±1.15 mV (Characteristic)
DC Offset Range (referenced to center of screen)	±500 mV
Input Dynamic Range (relative to channel offset)	±400 mV
Maximum Input Signal	± 2V (+16 dBm)
Nominal Input Impedance	50Ω

¹ Tuned to be -3 dB (±measurement uncertainty) at stated bandwidth(s) using NIST traceable swept-sine test system.

N1092A/B/C/D/E Horizontal Timebase Specifications

Item	Description
Scale Factor	Full scale is ten divisions
Minimum	100 fs/div
Maximum	100 μ s/div
Sample Delay ¹	< 10 ns
Time Interval Accuracy (in pattern lock mode)	$\pm 0.3\%$ of $1/(\text{clock input frequency})$ or ± 1.2 ps (whichever is smaller) (Characteristic) ² ± 150 fs $\pm 1\%$ of $1/(\text{clock input frequency})$ or ± 4 ps (whichever is smaller) ³
Time Interval Accuracy (in clock trigger mode)	$\pm 0.3\%$ of timespan or ± 1.2 ps (whichever is smaller) (Characteristic) ² ± 150 fs $\pm 1\%$ of timespan or ± 4 ps (whichever is smaller) ³
Time Interval Resolution ⁴	(screen diameter)/(record length) or 50 fs, whichever is larger
Jitter ⁵	
Option STB	400 fs rms (Characteristic) 450 fs rms
Option LOJ	160 fs rms (Characteristic) 200 fs rms
Display Units	Bits or Time
Record length	16 to 131,072 samples. Increments of 1
Sample rate ⁶	
Standard	Up to 100 kHz
Option FS1	Up to 250 kHz

¹ Time delay between the front panel clock input and when a sample is taken on the front panel channel input .

² Dual marker measurement performed at a temperature within $\pm 1\text{C}$ of horizontal calibration temperature.

³ Dual marker measurement performed at a temperature within $\pm 5\text{C}$ of horizontal calibration temperature.

⁴ The time interval resolution is the smallest time spacing between two points.

⁵ Verified with a clock slew rate greater than 40V/ns and optical signal slew rate greater than 150 μ W/ps.

⁶ Each channel samples at the specified sample rate regardless of the number of channels.

N1092A/B/C/D/E Clock Input Specifications

Item	Description
Clock Input Non-destruct Voltage	1.4 Vp-p
Clock Input Frequency	500 MHz to 32 GHz (full rate or sub-rate clocks, pattern lock mode on or off) 100 MHz to 500 MHz (sub-rate clocks only, pattern lock off, provided that the data rate exceeds 500 Mb/s and the clock divide ratio is a power of two)
Clock Input Sensitivity	200 mVp-p
Minimum Clock Slew Rate	0.5 V/ns
Nominal Input Impedance	50 Ω (AC coupled)
Clock Input Connector	2.92 mm (female)

N1092A/B (Option 40A) Clock Recovery Specifications with Option CDR

Item	Description			
Data Rates Input Range				
Option CDR	24 GBd - 29 GBd		48 GBd - 58 GBd	
Minimum Optical Modulation Amplitude (OMA) to achieve lock (Open eye) NRZ and PAM4 (OMA) 1310 nm/1550 nm, verified with clean open eye at 26.56 GBd and 53.125 GBd				
Option CDR	200 μ W			
	80 μ W at 26.56 GBd (Characteristic)			
	100 μ W at 53.125 GBd (Characteristic)			
PAM4 Stressed Eye 1310 nm/1550 nm (Clock recovery locks under these conditions)				
	Baud Rate	Pattern	Outer OMA	TDECQ
Option CDR	26.56 GBd	SSPRQ	-5.1 dBm (Characteristic)	~3.4 dB (Characteristic)
	53.125 GBd	SSPRQ	-0.8 dBm (Characteristic)	~3.4 dB (Characteristic)
Recovered Clock Out				
Amplitude	\geq 200 mVpp			
Divide ratio (user selectable)	1, 2, 4, 8, 16, 32			
Front panel connector type and interface	2.92 mm (m), 50 Ω , DC coupled			
Random jitter	200 fs maximum 150 fs @ 26.56 GHz (Characteristic)			
Clock recovery adjustable loop bandwidth range (user selectable)	0.5 MHz to 10 MHz (depends on Baud Rate)			
Clock recovery loop peaking range	Up to 4 settings (dependent on loop BW)			
Loop bandwidth accuracy ^{1, 2}	\pm 30%, (Characteristic)			
Acquisition range	\pm 300 ppm, (Characteristic)			
Maximum consecutive identical digits to lock	150 (Characteristic)			
Auto relocking	Yes (user enabled)			
Internal frequency counter accuracy	\pm 10 ppm 4 ppm (Characteristic)			
Clock Trigger Out (12.0 - 14.5 GHz)				
Amplitude	700mV (Characteristic)			
Frequency range	12.0 - 14.5 GHz			
Front panel connector type and interface	2.92 mm (m), 50 Ω , DC coupled			
Random jitter	80 fs (Characteristic)			

¹PLL bandwidth is calibrated and verified using clean 26.5625 GBd and 53.125 GBd NRZ and PAM4 signals with FlexDCA clock recovery loop tuning enabled.

²Actual PLL bandwidth may vary due to several factors, including pattern characteristics (low/high transition density), signaling format (NRZ/PAM4), and signal quality (open/closed eyes).

N1092A/B/C/D/E Environmental Specifications

Item	Description		
Use	Indoor		
Temperature			
Operating	+10°C to +40°C (+50°F to +104°F)		
Non-operating	-40°C to +70°C (-40°F to +158°F)		
Altitude (Operating)	Up to 4,600 meters (15,000 ft)		
Humidity ¹	Type tested at 95%, +40°C (non-condensing)		
Line Power	100/120Vac, 50/60/400 Hz		
	220/240Vac, 50/60 Hz		
	290 Watts Maximum		
	The products can operate with mains supply voltage fluctuations up to ±10% of the nominal voltage.		
Volts-Amperes (VA) (Characteristic)	Option 30A	Option 40A	Option CDR
N1092A	48 VA	48 VA	70 VA
N1092B	52 VA	50 VA	82 VA
N1092C	52 VA	52 VA	—
N1092D	60 VA	54 VA	—
N1092E	52 VA	54 VA	—
Weight (Characteristic)	Option 30A	Option 40A	Option CDR
N1092A	6.0 kg (13.4 lb)	6.0 kg (13.4 lb)	6.8 kg (15 lb)
N1092B	6.1 kg (13.6 lb)	6.1 kg (13.6 lb)	6.8 kg (15 lb)
N1092C	6.1 kg (13.6 lb)	6.1 kg (13.6 lb)	—
N1092D	6.3 kg (14.0 lb)	6.3 kg (14.0 lb)	—
N1092E	6.1 kg (13.6 lb)	6.1 kg (13.6 lb)	—
Dimensions			
Without front connectors and rear feet	88.26 mm H x 207.40 mm W x 485 mm D (3.48 inch x 8.17 inch x 19.01 inch)		
With front connectors and rear feet	103.31 mm H x 219.56 mm W x 517.80 mm D (4.07 inch x 8.64 inch x 20.39 inch)		
With front cover and rear feet	110.18 mm H x 219.56 mm W x 550.71 mm D (4.34 inch x 8.64 inch x 21.68 inch)		

1. Samples of this product have been type tested in accordance with the Keysight Environmental Test Manual and verified to be robust against the environmental stresses of Storage, Transportation and End-use; those stresses include but are not limited to temperature, humidity, shock, vibration, altitude, and power line conditions. Test Methods are aligned with IEC 60068-2 and levels are similar to MIL-PRF-28800F Class 3.

Ordering Information – N1092A/B/C/D/E

The legacy FlexDCA feature-based software options such as 200, 201, etc. have been replaced with the following new FlexDCA Sampling Oscilloscope Software Packages:

N1010100A Research and Development Package for FlexDCA Sampling Oscilloscope Software

This package is Intended for R&D engineers who want to characterize their design and gain more insights into why a signal deviates from the expected performance.

N1010200A Manufacturing Package for FlexDCA Sampling Oscilloscope Software

This package focuses on cost of test in Optical Transceiver manufacturing applications with capabilities like RapidEye and FlexEye that enhance measurement speed and flexibility and includes measurements like TDECQ.

N1010300A Signal Integrity Package for FlexDCA Sampling Oscilloscope Software

This package adds powerful tools to measure impedances, transfer characteristics and S-parameter calculations to the basic TDR/TDT measurements.

Keysight recommends the use of the above FlexDCA software PACKAGEs which can be installed on the PC controlling your DCA-M (they cannot be installed directly on the DCA-M).

The legacy FlexDCA feature-based software options such as 200, 201, etc. in the option table below are available for a limited time and can be installed by the factory on your new DCA-M.

Support subscriptions are available for FlexDCA software PACKAGEs which enable both bug fixes and new functionality. The software FEATURE-based options will get no new functionality.

The following table lists the N1092X-series models along with ordering options.

NOTE: For additional details regarding configuring your N1092X DCA-M, refer to the *DCA Wide-Bandwidth Oscilloscope Family Configuration Guide* available on Keysight.com.

Model/option number	Description
N1092A	Single optical channel oscilloscope
N1092B	Dual optical channel oscilloscope
N1092C	Single optical, dual electrical channel oscilloscope
N1092D	Quad optical channel oscilloscope
N1092E	Dual optical, dual electrical channel oscilloscope
N1092x-30A	30 GHz amplified
N1092x-40A	> 40 GHz amplified (includes an unfiltered path and 53 GBd PAM4 TDECQ filter)
N1092x-280	25.781, 27.739, 27.952, 28.050 Gbaud filters (mandatory)
N1092x-LOJ	Low jitter timebase
N1092x-STB	Standard timebase
N1092x-PLK	Pattern lock capability
N1092x-FS1	Fast sampling rate
N1092x-200	Enhanced jitter analysis software, fixed perpetual license
N1092A/B-CDR	25 to 29 GBd and 53 to 58 GBd Clock data recovery
N1092x-201	Advanced waveform analysis software, fixed perpetual license
N1092x-300	Advanced amplitude analysis/Rin/Q-Factor, fixed perpetual license
N1092x-401	Advanced eye analysis software, fixed perpetual license
N1092x-500	Productivity package, fixed perpetual license
N1092x-9FP	PAM-N analysis SW, fixed perpetual license
N1092x-TFP	IEEE TDECQ analysis, fixed perpetual license

N1092x-PLK	Pattern lock trigger hardware
N1092x-IRC	Impulse response correction
N1092x-EFP	FlexEye Independent Channel Acquisition and Control
N1092x-SIM	InfiniiSim-DCA waveform transformation SW, fixed perpetual license
N1092x-168	Additional 25.78 Gb/s TDEC filter (requires Option 500)
N1092x-206	Additional 20.625 Gb/s filter
N1092x-C0C	Certificate of Calibration
N1092x-UK6	Commercial calibration certificate with test data
N1092x-1CM	Single instrument rack mount kit
N1092x-1CN	Dual instrument side-by-side rack mount kit

N1010A FlexDCA software is required on the PC controlling the N1092A/B/C/D/E DCA-M. It is available as a free download at www.keysight.com/find/flexdca_download.

www.keysight.com/find/n1092a

Learn more at: www.keysight.com

For more information on Keysight Technologies' products, applications or services, please contact your local Keysight office. The complete list is available at:

www.keysight.com/find/contactus

