

Sorensen

DLM 600

Near Linear 600W DC Power Supply



NOW AVAILABLE WITH ETHERNET

Applications

- Electronic Design/Development
- Battery Charging
- Process Control
- Rackmount ATE Systems



DLM 600

Near Linear Power Supply

The DLM 600W Series of programmable power supplies is designed to provide continuously variable output voltage and current for a broad range of applications in a compact 1U (1.75 inches) high, half-rack (8.5 inch) wide chassis.

With the use of Zero Voltage Switching (ZVS) technology, these supplies are able to achieve exceptionally low ripple and noise rivaling larger and more expensive linear power supplies. In addition, the high efficiency and fast load transient response assure the DLM is ideal for even the most demanding applications.

The DLM 600W Models are ideal for high density multiple output rackmount requirements or low profile benchtop applications. Output voltages from 0-5VDC to 0-300VDC and currents from 0-2A to 0-75A are available.

The cooling air intake is at the front and sides with exhaust at the rear and sides. Variable speed fans are controlled as a function of ambient air temperature and load, thus reducing acoustic noise and increasing fan life. This allows supplies to be stacked one directly on top of another without space in between, yielding maximum rackmount packing density and a wide operating temperature of 0-50° C. An optional rackmount kit is available to easily mount one or two units side-by-side.

The front panel layout makes the DLM 600W Series easy to use. Voltage and current can be set from individual 10-turn potentiometer knobs. Control push buttons include power on, output on, local/remote, voltage/current preview and overvoltage protection preview. Set-point or actual voltage/ current values can be viewed on two 3.5 digit LED displays.

Supplies can be connected in series or parallel. All models automatically accept any standard single phase input without manual set up.

DLM 600 Key Features

- **High Power Density**
600 watts in 1U (1.75 inches) high, half rack (8.5 inches) wide; no top or bottom clearance spacing required.
- **Wide Range of Output Voltages**
0-5V, 8V, 10V, 20V, 40V, 60V, 80V, 150V and 300V.
- **Low Ripple & Noise**
Ripple as low as 2.5mV RMS, noise as low as 15mV p-p.
- **Optional Digital Control**
 - Ethernet LAN / RS232C (16 bit)
 - IEEE-488.2 / RS232C (12 bit)
- **Fast Transient Response**
Recovers in less than 500 μ s for a 50-100% or 100-50% load change.
- **Preview Pushbutton**
Overvoltage protection, voltage and current preview buttons allow viewing these set points at any time with or without the output enabled.
- **Efficiency**
84% typical at maximum output power.
- **Built-In Down Programming**
Standard internal circuitry to speed up response time to down programming changes.
- **Autoranging Input Voltage**
Universal AC input.
- **Remote Voltage Sense**
Sense leads are easily connected to a solderless rear panel connector.
- **Remote Analog Operation**
Standard analog programming 0-5V, 0-10V, or 0-5k Ω .
Optional isolated analog programming (M51A)
- **Operating Modes**
Constant voltage and constant current with autocrossover and LED indicators.
- **Simple master/slave paralleling, active current sharing.**
- **CE Mark**
- **5 Year Warranty**

DLM 600

Common Specifications

VOLTAGE/CURRENT RANGES

Model	Voltage	Current
DLM 5-75	0-5V	0-75A
DLM 8-75	0-8V	0-75A
DLM 10-60	0-10V	0-60A
DLM 20-30	0-20V	0-30A
DLM 40-15	0-40V	0-15A
DLM 60-10	0-60V	0-10A
DLM 80-7.5	0-80V	0-7.5A
DLM 150-4	0-150V	0-4A
DLM 300-2	0-300V	0-2A

OUTPUT

Ripple & Noise:

See table on page to the right.

Line Regulation:

Voltage: 0.005% of V max + 2 mV
 Current: 0.01% of I max + 2 mA
 See table on page to the right.

Load Regulation:

Voltage: 0.005% of V max + 2 mV
 Current: 0.02% of I max + 5 mA
 See table on page to the right.

Transient Response:

500 μ s to steady-state output voltage (within 0.1% of Vmax) for 50-100% or 100-50% load change

Stability:

\pm 0.05% of maximum voltage or current over 8 hours after 30 minute warm-up time at fixed line, load and temperature

Efficiency:

84% typical at maximum output power; 82% typical for DLM 5-75 and DLM 8-75

Temperature Coefficient:

0.02%/°C of maximum output voltage, 0.03%/°C of maximum output current

INPUT

Voltage and Frequency:

90-132 VAC or 180-264 VAC max, auto ranging, 47-63 Hz, single phase, 2-wire plus ground

Current:

11A maximum at 115VAC, 6A maximum at 230 VAC

Connector:

IEC 320 with detachable line cord

GENERAL

Operating Temperature:

0°C to 50°C

Storage Temperature:

-40°C to 65°C

Cooling:

Internal variable speed fans with overtemperature protection. Air intake is from the front and sides with exhaust at rear and sides for maximum rackmount packing density.

Remote Sense:

The maximum allowed load line drop with remote sensing is 1V total for DLM 5-75 and DLM 8-75 model, 2V total for all other models.

Remote Programming:

Voltage, current (0-100%) and OVP (5-110%) of full scale can be programmed by selectable 0-5VDC, 0-10VDC, or 0-5k Ω

Remote Monitoring:

Voltage or current can be monitored with user-selectable ranges, scaled to 0-5 VDC or 0-10 VDC

Operational Features:

Master/slave parallel operation, up to 4 units of the same model can be connected in parallel, with active current sharing control. Series operation, multiple units of the same model can be connected in series, limited by 300Vpk between either output terminal and chassis.

Ethernet/LAN Option: (M130)

- 10/100 base-T
- TCP/IP Protocol
- ICMP (Ping Server)
- Web Server: Direct control of power supply via standard web browser.

Disconnect/Polarity Relay Option: (M6)

Output disconnect and polarity reversal relays controlled via SCPI commands. Single SPST relay in line with each output lead.

Rated life: 100 Million operations, mechanical; 100,000 at 70Amps 14Vdc resistive load.

Software:

IVI-COM, LabVIEW® or LabWindow/CVI driver for Ethernet and IEEE-488.2 can be downloaded at no cost at: www.elgar.com.

Regulatory Compliance:

CE Compliant:

- Low Voltage Directive (73/23/EEC) using EN 61010-1, and
- EMC Directive (89/336/EEC) using EN 61326

Certified to UL 61010-1, CSA C22.2 No. 61010.1 and IEC/EN 61010-1

Dimensions:

1U or 1.75" (44 mm) H x 8.5" (216 mm) W x 17" (432 mm) D, Option M6 depth 20" (508 mm)

Weight:

9.7 lbs. (4.4 kg)

Shipping Weight:

12.7 lbs. (5.8 kg)

J1 Connector	
1	ANALOG-CONTROL Input
2	EXTERNAL-OFF Return
3	OVP Programming Input
4	REMOTE-CONTROL Status Output
5	VOLTAGE-MODE Status Output
6	Auxiliary 5 VDC Return
7	Current Monitor Output
8	Voltage/Current Monitor Return
9	Voltage Programming Input
10	Current Programming Input
11	Not Used
12	V/I/OVP Programming Return
13	Not Used
14	EXTERNAL-OFF Input (+)
15	Auxiliary 5 VDC Output (+)
16	OVP Resistance Programming Output
17	OVP Resistance Programming Return
18	FAULT Status Output
19	Voltage Monitor Output
20	Voltage Resistance Programming Return
21	Voltage Resistance Programming Output
22	Current Resistance Programming Output
23	Current Resistance Programming Return
24	LOCAL-LOCKOUT Input
25	OVP Status Output

OPTIONS & ACCESSORIES ACCESSORIES

Remote Interface Options	
M6	Disconnect & Polarity reversal relays (10V to 300V models only. This option requires at least one of the following options: M9G, M85, M130 or M131)
M9G	IEEE-488.2 and RS 232 Interfaces
M13	Locking shafts (front panel potentiometers)
M51A	Optically Isolated Analog Programming and Monitoring
M85	Multichannel Slave Interface
M130	Ethernet/LAN and RS232C Interfaces (16 bit)
M131	Multichannel Slave Interface (16 bit) (M130 Master ONLY)

Parallel Cable	
DLMP1	Paralleling Cable; one cable per slave unit
Rackmount Kit	
DLMRK	Rackmount Kit for single DLM with filler panel and for two units mounted side-by-side



Model	Output Ratings			Line Regulation		Load Regulation	
	Voltage (VDC)	Current (ADC)	Power (Watts)	Voltage (0.005% of Vmax + 2 mV)	Current (0.01% of Imax + 2 mA)	Voltage (0.005% of Vmax + 2 mV)	Current (0.02% of Imax + 5 mA)
DLM 5-75	0-5	0-75	375	2.4mV	9.5mA	2.4mV	20mA
DLM 8-75	0-8	0-75	600	2.4mV	9.5mA	2.4mV	20mA
DLM 10-60	0-10	0-60	600	2.5mV	8mA	2.5mV	17mA
DLM 20-30	0-20	0-30	600	3mV	5mA	3mV	11mA
DLM 40-15	0-40	0-15	600	4mV	3.5mA	4mV	8mA
DLM 60-10	0-60	0-10	600	5mV	3mA	5mV	7mA
DLM 80-7.5	0-80	0-7.5	600	6mV	2.8mA	6mV	6.5mA
DLM 150-4	0-150	0-4	600	9.5mV	2.2mA	9.5mV	5.8mA
DLM 300-2	0-300	0-2	600	17mV	2.1mA	17mV	5.4mA

Model	Programming Accuracy †						Display Accuracy	
	Ethernet (M130/M131)			GPIB (M9G/M85)			Voltage (0.5% of Vmax + 1 count)	Current (1.0% of Imax + 1 count)
	Voltage (0.1% of VMax)	Current (0.25% of IMax)	OVP (0.5% of 1.1 x Vmax)	Voltage (0.2% of VMax)	Current (0.5% of IMax)	OVP (1.0% of 1.1 x Vmax)		
DLM 5-75	8mV	188mA	44mV	16mV	375mA	55mV	35mV	850mA
DLM 8-75	8mV	188mA	44mV	16mV	375mA	88mV	50mV	850mA
DLM 10-60	10mV	150mA	55mV	20mV	300mA	110mV	60mV	700mA
DLM 20-30	20mV	75mA	110mV	40mV	150mA	220mV	200mV	400mA
DLM 40-15	40mV	38mA	220mV	80mV	75mA	440mV	300mV	160mA
DLM 60-10	60mV	25mA	330mV	120mV	50mA	660mV	400mV	110mA
DLM 80-7.5	80mV	19mA	440mV	160mV	38mA	880mV	500mV	85mA
DLM 150-4	150mV	10mA	825mV	300mV	20mA	1.65V	850mV	50mA
DLM 300-2	300mV	5mA	1.65V	600mV	10mA	3.3V	2.5V	30mA

† Readback accuracy is the same as programming accuracy for all parameters except GPIB Voltage readback

Model	Ripple and Noise, Voltage Mode		OVP Adjustment Range (5% - 110% of Vmax)	Stability		Temperature Coefficient		Maximum Total Remote Sense Drop
	Ripple (RMS)*	Noise (P-P)*		Voltage (0.05% of Vmax)	Current (0.05% of Imax)	Voltage (0.02%/°C of Vmax)	Current (0.03%/°C of Imax)	
DLM 5-75	5mV	30mV	0.25-5.5V	2.5mV	37.5mA	1mV/°C	22.5mA/°C	1V
DLM 8-75	5mV	30mV	0.4-8.8V	4mV	37.5mA	1.6mV/°C	22.5mA/°C	1V
DLM 10-60	5mV	30mV	0.5-11V	5mV	30mA	2mV/°C	18mA/°C	2V
DLM 20-30	2.5mV	15mV	1-22V	10mV	15mA	4mV/°C	9mA/°C	2V
DLM 40-15	2.5mV	15mV	2-44V	20mV	7.5mA	8mV/°C	4.5mA/°C	2V
DLM 60-10	2.5mV	20mV	3-66V	30mV	5mA	12mV/°C	3mA/°C	2V
DLM 80-7.5	4mV	20mV	4-88V	40mV	3.75mA	16mV/°C	2.25mA/°C	2V
DLM 150-4	7mV	40mV	7.5-165V	75mV	2mA	30mV/°C	1.2mA/°C	2V
DLM 300-2	10mV	60mV	15-330V	150mV	1mA	60mV/°C	0.6mA/°C	2V

* RMS noise typical from 20 Hz to 20 MHz

** Specifications in red are improved.

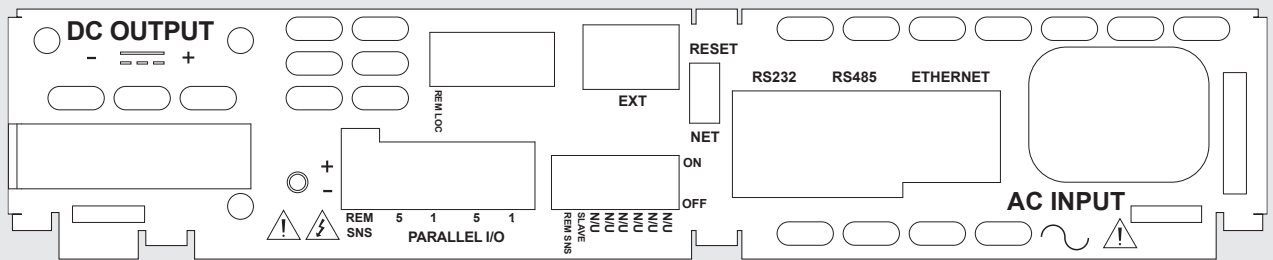
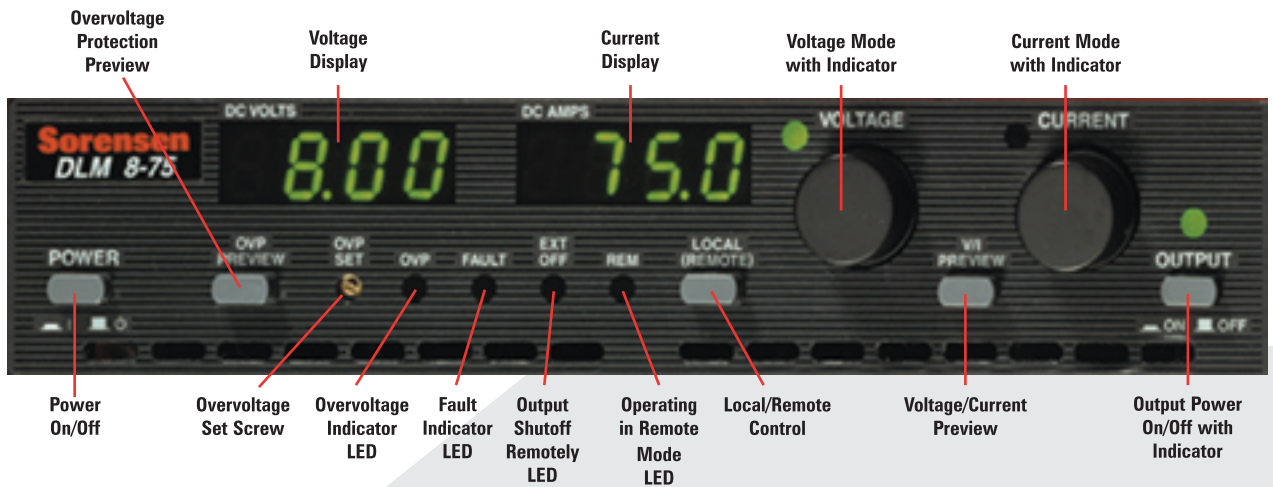

Multi-channel Slave Interface

The multichannel slave interface option, provides the user a method to simplify system design when multiple power supplies are required. Utilizing a single power supply with either Ethernet, IEEE-488.2 (GPIB) or RS232C, up to 30 additional supplies may be controlled via a daisy chained RS485 interface. Group commands may be sent to all supplies simultaneously to reduce command latency, as well as being able to address each supply individually. With the RS485 interface, distances to the slaves may be extended well beyond the typical limitations for IEEE-488.2 systems.

Key features include:

- Single Ethernet, IEEE-488.2 or RS232C address for up to 31 power supplies
- Lower system costs through reduced cabling and development time
- Long cable distances between controller and power supplies



Ethernet / LAN,
IEEE-488.2/GPIB or RS232C



DLM 600: Drawings

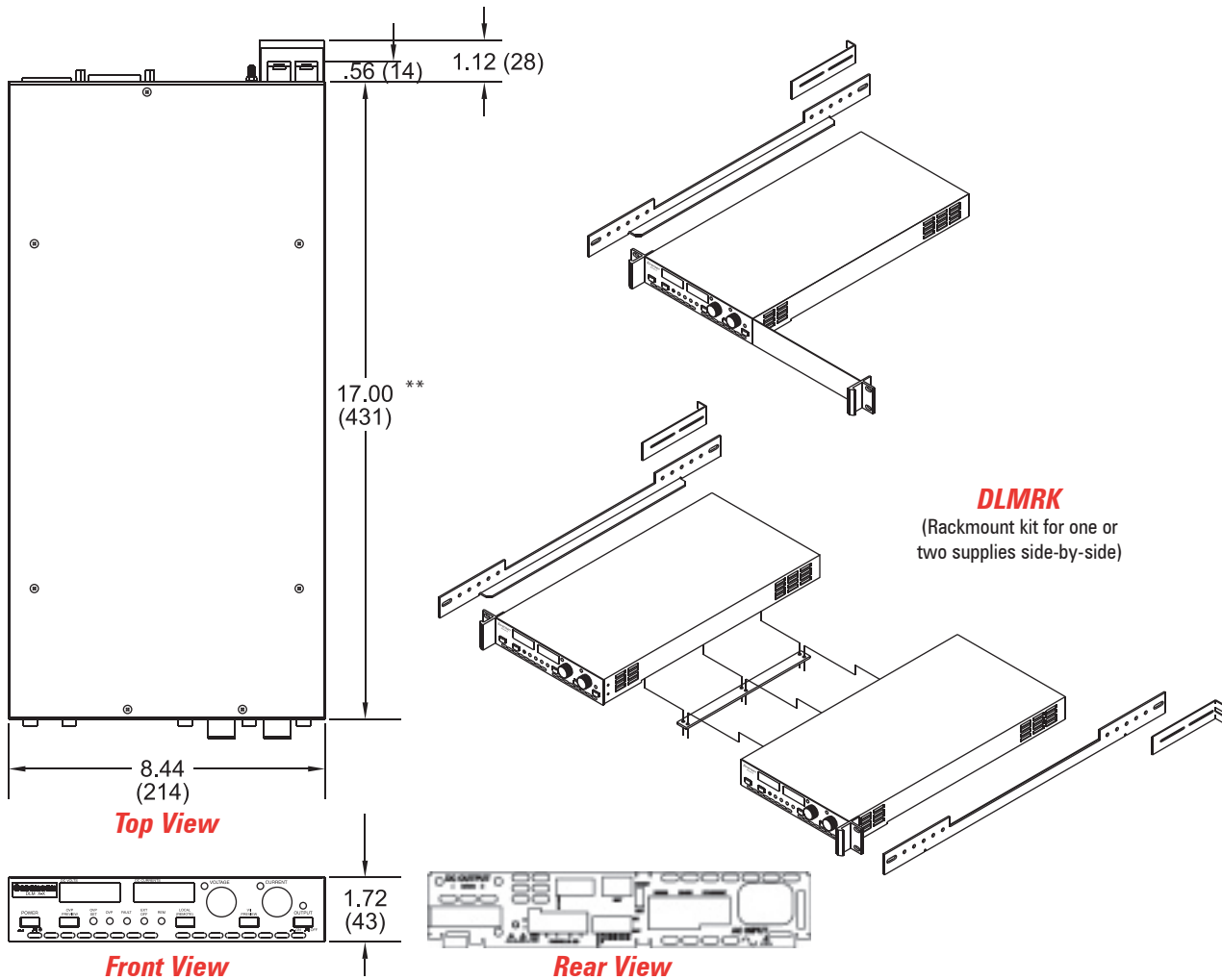

Dimensions in inches (millimeters)

* 80V, 150V and 300V models have two position terminal blocks for the output
 ** M6 Option: 20" (508 mm).

DLM 600: Model Number Description

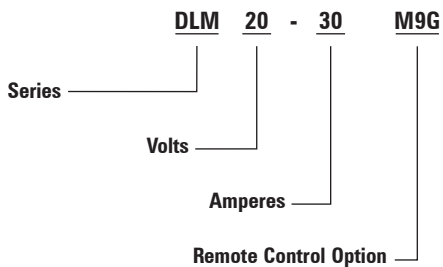

- M6: Disconnect & Polarity reversal relays (10V to 300V models only)
- M9G: IEEE-488.2 and RS232C Interface
- M13: Locking shafts (front panel potentiometers)
- M51A: Optically Isolated Analog Programming and Monitoring
- M85: Multichannel Slave Interface
- M130: Ethernet/LAN and RS232C Interfaces
- M131: Multichannel Slave Interface (M130 Master ONLY)



POWER EVOLVED

ELGAR Sorensen POWERTECH

Elgar Electronics Corporation • 9250 Brown Deer Road, San Diego, CA 92121
 Toll Free: 800-733-5427 • Tel: 858-450-0085 • Fax: 858-458-0267 • www.elgar.com • sales@elgar.com