

AuroraSonata

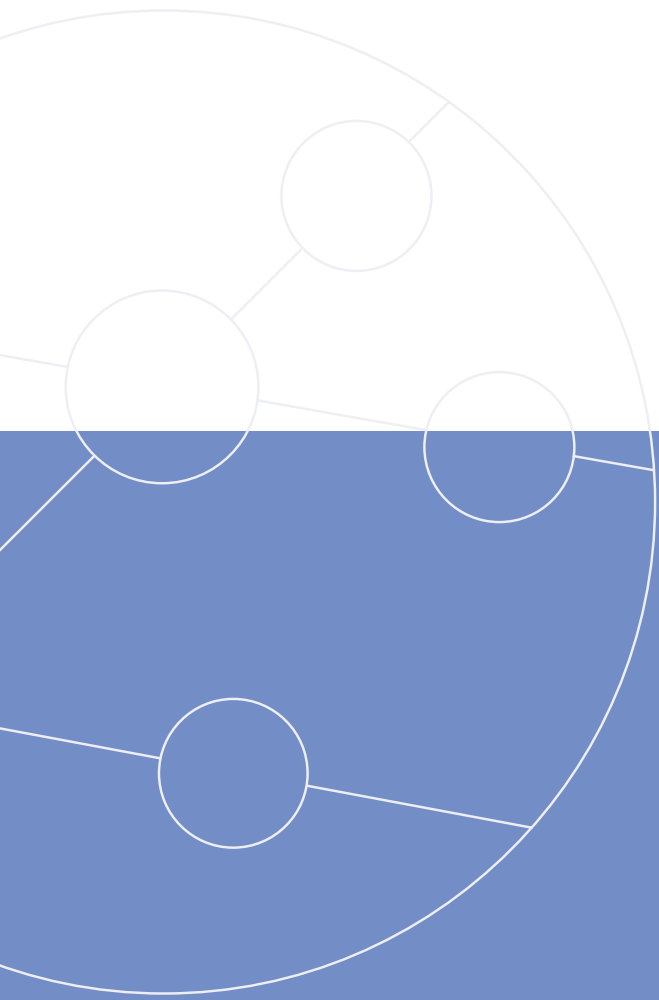

ISDN Test Equipment



ISDN

Hand-held testing for Primary & Basic Rate



TrendCommunications

The Trend **AuroraSonata** represents a significant advance in the capability of ISDN testers. Conceived as an all purpose test tool, it has the functionality to meet and surpass the field technician's growing demands on an ISDN Installation and Maintenance Tester.

The **AuroraSonata** is handheld, easy to use, rugged, and above all, has a radical modular design making it suitable for digital communications networks both now and in the foreseeable future.

AuroraSonata and its rugged, but style weather and scratch resistant construction, is designed to withstand a 2 metre drop.

The **AuroraSonata** is a key asset in all business activities involving ISDN, its straightforward operation translates into quicker resolution of problems and savings in time and expense. Service providers can make extensive use of the LT emulation and the monitoring functions associated with the 'U' interface. Organisations

concerned with the commissioning and installation of ISDN equipment can profit from the NT and TE simulation capability. Companies involved with maintenance and problem solving will find the monitoring and decoding functionality invaluable, especially where NT deregulation has taken place and the aurora's NT 'swap-out' mode can be used. And, of course, the **AuroraSonata** has protocols for private and proprietary networks enabling engineers to work on any class of ISDN network with the same tool. Even users of ISDN services can use the **AuroraSonata** to ensure that the services are as expected and as an arbitration tool in the event of dispute between different suppliers in their ISDN environment.

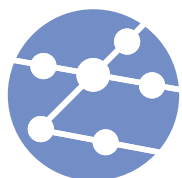

AuroraSonata

The evolution of ISDN testing

The design of the **AuroraSonata** makes it ideal for all applications and conditions that installation and maintenance engineers in the field can experience. This modular approach means that you can configure today for today's needs, and know the tester will develop for tomorrow's. Its software is field upgradable, and new interfaces can be added locally.

Much thought has gone into the actual operating requirements of the tester. The need to have ease-of use has been a major consideration to make the whole testing process quick and simple. The logically constructed menus for configuration and operation are supplemented by single key selections for commonly needed functions, and the pre-configured test suites for service tests definitely save time. The unit's size and design means that virtually any location where it is possible to install ISDN equipment is accessible to an engineer with an



What are the key testing applications?

Simulation & Monitoring. . .

behaving as, and looking at any part of the local network can identify where a problem exists.

Simulation

The **AuroraSonata** can simulate on the Basic Rate 'S/T' or 'U' reference points allowing a full combination of TE, NT and LT modes including EOC loopback commands and on the Primary Rate interface in TE or NT mode, either directly on the exchange or at customer premises.

This means the **AuroraSonata** can test virtually any point on the ISDN. The unique 'One Button Test Suites' can verify B-Channel Provisioning, Line Quality, Teleservice and Supplementary Service availability. Primary Rate simulation offers, in addition, full and outgoing channel tests.

Multi-channel simulation:

- B1, B2, Bx channel selection in Basic Rate modes
- Establish up to 30 simultaneous calls in Primary Rate modes

Monitoring

The **AuroraSonata** can monitor B-Channel voice and D-Channel signalling on the PRI 'T' and on Basic Rate 'S/T' and 'U' Reference Points, allowing you to trouble- shoot in-service ISDN lines anywhere on the network. D-Channel decode is displayed on screen in real-time and can be saved in memory or downloaded to the **AuroraExpert** for Windows package for detailed analysis.

AuroraSonata Simulation Modes

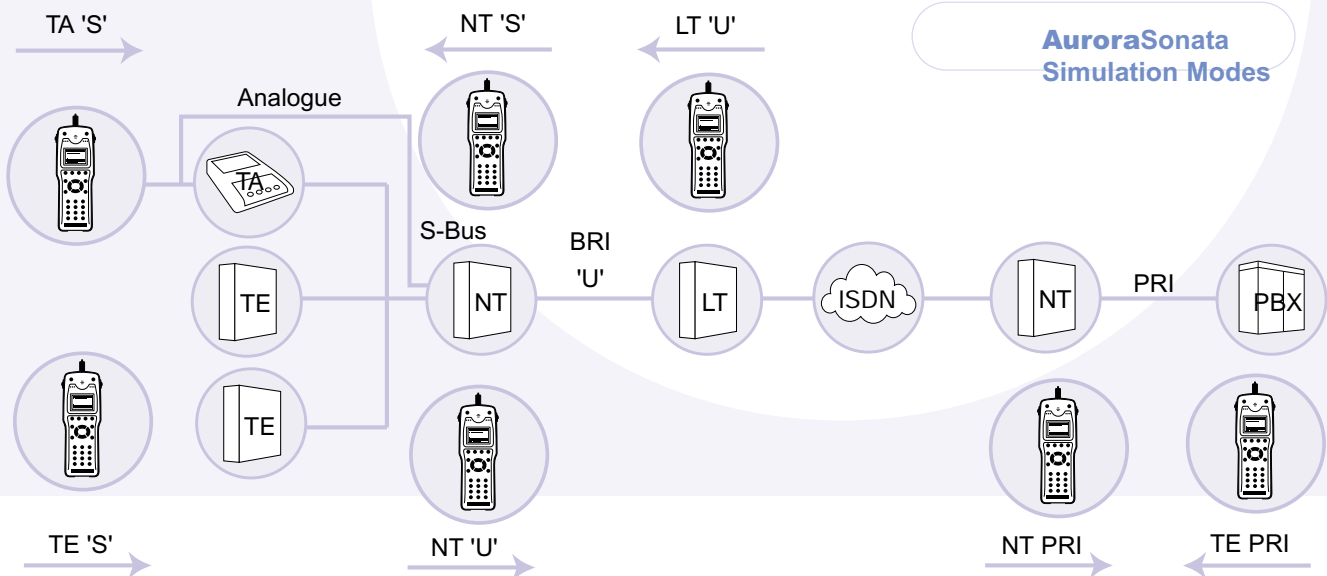

NT 'Swap-out' mode – used where there is access to an NT1 which may be suspected as being faulty. The **AuroraSonata** may be substituted for the NT to allow D-Channel signalling to be viewed whilst normal call establishment is allowed to proceed.

As part of its diagnostics, the **auroraSonata** will also display textual cause code reasons and wherever possible, network location thus making the job of problem solving that much easier.

Physical layer testing

In addition to Context Sensitive LEDs, Layer 1 information is displayed, allowing quick diagnosis of problem circuits. Comprehensive information on current states and number of occurrences of the following layer 1 errors; NOS (No Incoming Signal), AIS (Alarm Indication Signal Received), LOS (Loss of frame Synchronisation), CRC (Cyclic Redundancy Check), E (Number of multi-frames with CRC errors at

remote), Slips (Number of frame slips), FAS Error (Number of erroneous FAS words) and HDB3 CV (Number of HDB3 code violations). The content of FAS (Frame Alignment Signal) and NFAS (Non-frame Alignment Signal) words can be viewed. The **AuroraSonata** has extensive BERT capabilities including simultaneous operation using full bandwidth available.

- Automatic Service Tests suites for one key testing
- Check the line configuration
- Validates operation across all channels

Teleservice & Supplementary Service Testing

Identifies which services are available on the line under test and therefore those which are not.

Keypad support for * and #; Hold/Retrieve; Call Waiting; Forwarding (CFU, CFB, CFNR); Completion; Closed User Group; Terminal Portability; 3 Party and Conference Calls; Malicious Call ID; Origination and display of Calling Line Identity (CLIP), Connected Line Identity (COLP), Charging information; Validates operation of Direct Dialling In (DDI), Multiple Subscriber Numbers (MSN), User to User information, Alpha-numeric sub-addressing.

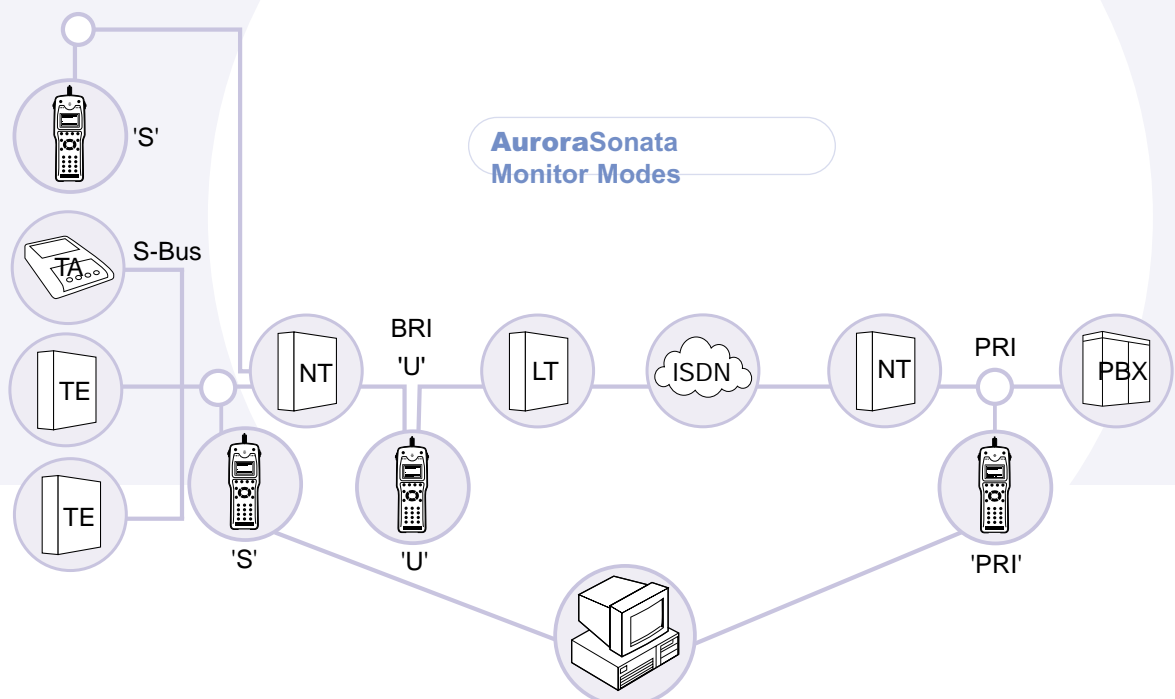

Protocol Monitoring, Trace and Analysis

It's not enough to know what is wrong, it's knowing why it's wrong. Capture the awkward, intermittent errors that cause the underlying problems.

- On-screen Real time decode and trace of D-Channel activity provides instant identification of errors. Freeze display whilst continuing to capture data
- Expand mode to view all protocol events
- Onboard storage of data for subsequent analysis with **AuroraExpert**, enables less experienced technicians to collect traces from network
- Filters allow specific protocols to be selected with frame timestamps for accuracy of transmission recording
- Many filter criteria including layer, call reference, SAPI, TEI, and many more to define exactly the required data

International, National and Private protocols

International, National and Private protocols – enables engineers to work on a variety of equipment and mixed protocol networks without using a different tester.

● ETSI, EDDS1-VN, 1TR6, Comet-T, Comet-N, Comet-TS, TN1R6-T, TN1R6-N DASS2, DPNSS, X25

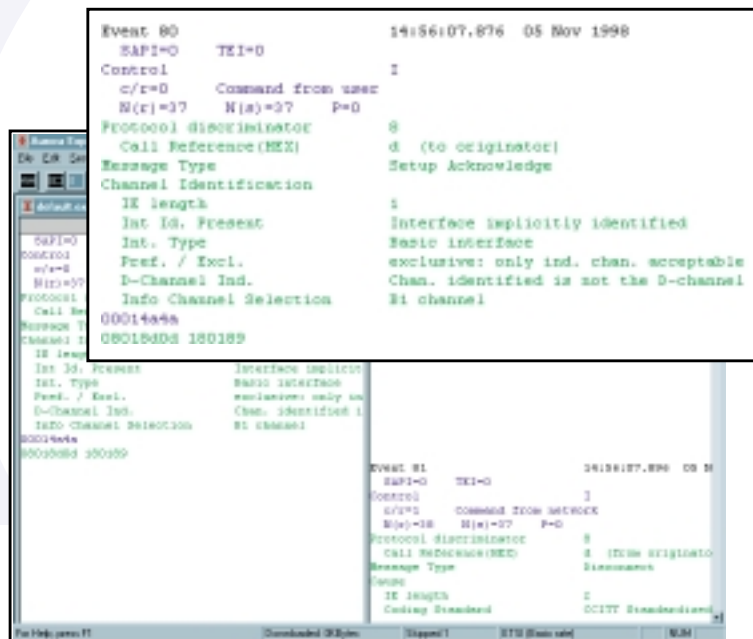

V5 Protocol monitor

With access networks providing the means to accommodate mixed technologies across multiple E1 spans, monitoring and decoding the traffic over these interfaces is crucial in determining where cross protocol errors may occur.

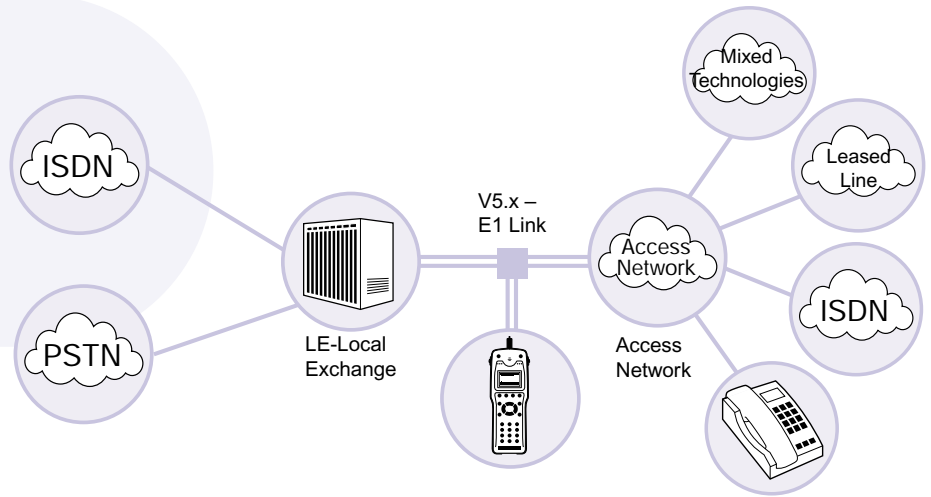

- Fully decode all V5.1 and V5.2 protocols
- PSTN Protocol, Control Protocol, Link Control Protocol, Bearer Channel Control Protocol, Protection Protocol and the Encapsulated LAPD Protocol (ISDN + X25)
- Decode encapsulated ISDN and X.25 signalling (user signalling)

HDSL System Testing

With the development of HDSL lines as a medium of transporting Primary Rate ISDN access, the auroraSonata is able to simulate the various components in the system.

- LT, NT and TE simulation
- 1 or 2 pair testing
- Physical testing, such as Attenuation and SNR
- Test functions and features of Primary rate payload
- NT Swap-out

Advanced POTS facilities

The **AuroraSonata** enables the engineer to test and monitor POTS circuits. The functionality provided here is not simply to identify POTS circuits but to actively test their operation, in many cases relieving the need to carry additional test equipment.

- Called party Number facility provides for both on and off-line editing
- Call Information: CPN
CLI (where available)
Charging
Line Voltage
Ringing Voltage
- Tracer Support for local decode, **AuroraExpert** and Debug

The **AuroraSonata** will simulate POTS terminal equipment onto the network, providing incoming and outgoing call facilities, capturing the call detail and providing review/decode of those captured details.

The engineer will be able to monitor audio on POTS circuits through the inbuilt speaker.

Multiple Interface capability

Needed for combined BRI/PRI operation, POTS, and 'U' interface monitoring. Selected physical interface is indicated by LED at the base of the unit.

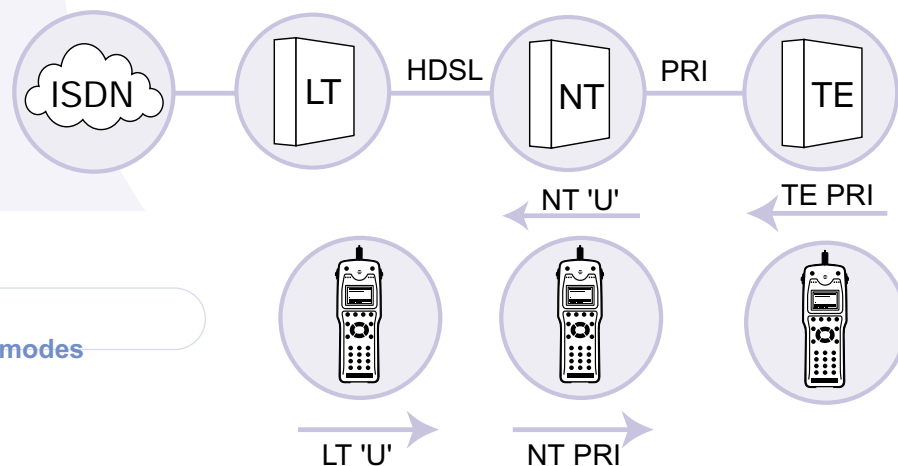

AuroraSonata
HDSL Simulation modes

Aurora Sonata

Physical Measurement	Voltage measurement across common mode pairs	Display G.703/G.704 statistics and FAS/NFAS word
Voice	3.1KHz and ISDN voice calls on user selected B-Channel. With manual or automatic answer.	
Data	Automatic answer. Wide range of Teleservices. Auto/Manual Bit Error inject. Loop of Receive to Transmit data.	
Test Length	10 secs, 1 min, 15 mins, 1 hr, continuous User defined.	
Test Pattern	8 selectable & user defined	
Results: (Displayed as per G.821)	Bits received, Bit Errors, Bit error ratio, Errored seconds, Error Free seconds, Severely Errored Seconds, Unavailable Seconds, Degraded Minutes, Elapsed time, Sync losses	
Protocol	Display of call progress and textual explanation of clear/fail causes. Monitor and Tracer facility giving time stamped three layer decode to screen or printer port.	
Interfaces	S/T: 192Kbps to ITU 1.430	ITU G.703 2.048Mbps
Connectors	RJ45 connector	75ohm unbalanced/120ohm balanced RJ45
	FCC 68 4-4 for external clock	
	RJ11 for audio input/output	
Clocking	Recovered from line. Internally generated. Generated from external source.	Transmit clock recovered from received data. Internally generated 2.048Mbps ± 10 ppm. Supplied from external source Coding HDB3, CRC4 on/off.
U Interface (Individual hardware required for each different interface)	2B1Q, 4B3T, Up0	
Indicators	Line Activation Status Battery Charge/Low Level BERT Sync HDB3 Status CRC4 Status	
POTS I/F	DTMF identifying the most recently received tones CLASS identifying the last received V23 encoded CLI or call waiting CLASS service CHARGE counting the number of charge pulses received Line Voltage DATA (absent or present) showing data outside the normal audio frequency range for voice has been detected on the line	
Display	Backlit display 21 characters by 8 lines	
RS232	Asynchronous selectable to 115.2Kbps	
Ethernet	285mm(l) x 100mm(w) x 87mm(d)	
Size	1.1kg with single interface	
Weight	-15oC to 55oC	
Operating temperature	-25oC – 70oC (ETSI 300 019 – 1-1 class 1.2)	
Storage temperature	IP22 - water ingress Drop test - 2m	
Humidity	Rechargeable NiMH battery. Supplied with 220/240 VAC to DC adaptor.	
Case design	Large Carry Case	
Options	Phantom Power Feed boxes	





Trend Communications Ltd
Knaves Beech Estate
Loudwater
High Wycombe
Buckinghamshire
HP10 9QZ
United Kingdom

TrendCommunications

International: +44 (0)1628 524977
United Kingdom: 01628 524977
France: 01 69 35 54 70
Deutschland: 089 32 30 09 11
Italia: 02 73 91 414
España: 93 300 3313
India: 022 859 7463
Email: infoline@trendcomms.com
Web: www.trendcomms.com

A Member of the Telematrix plc Group



Distributor

To arrange a demonstration or to obtain the latest information on the Trend **Aurora** Sonata or any of Trend's other test equipment, contact your nearest Trend Distributor.

Trend **Aurora** is a registered trade mark of Trend Communications Ltd.