

7062  
7063

- 500MHz bandwidth
- BNC connectors
- Two independent 1 of 5 switches

### Ordering Information

7062	RF Switch Card
7063	RF Switch Card with Terminations

7064



- <math>1\mu\text{V}</math> contact potential
- 2-pole Form A relays
- Screw terminal connections

### Ordering Information

7064	20-Channel Low Voltage Scanner Card
------	-------------------------------------

## 500MHz RF Switching Cards

Model 7062, 50 $\Omega$  unterminated

Model 7063, 50 $\Omega$  terminated (on unselected inputs)

The 7062 and 7063 have two independent 1 of 5 switches. Each switch has a separate through connection that can be used to cascade sections to achieve larger scanning configurations in multiples of five. The switched transmission line design maintains the 50 $\Omega$  characteristic through the switch, minimizing reflection and loss. This approach results in reduced capacitance and better frequency response. The 7063 inputs are terminated in the 50 $\Omega$  characteristic impedance when not selected. A 500MHz bandwidth assures signal integrity over a broad range from DC to communications signals and digital waveforms. Coaxial switching provides additional shielding and noise immunity in the system environment.

**SWITCHES PER CARD:** 2 (with isolated grounds).

**CHANNELS PER SWITCH:** 5.

**SWITCH CONFIGURATION:** 1-pole, 5 throw.

**EXPANSION:** A through connector is provided for cascading switches.

**CONNECTOR TYPE:** BNC.

**RELAY DRIVE CURRENT:** 100mA per relay typical.

**ACTUATION TIME:** 10ms exclusive of mainframe.

**RELEASE TIME:** 5ms.

**CHARACTERISTIC IMPEDANCE:** 50 $\Omega$ .

**TERMINATIONS:** 7062: None. 7063: 50 $\Omega$  on unselected inputs.

**PROPAGATION DELAY:** <math>2\text{ns}</math>.

**INSERTION LOSS:** <math>0.1\text{dB}</math> below 20MHz, <math>1.0\text{dB}</math> below 250MHz, and <math>3.0\text{dB}</math> below 500MHz.

**ISOLATION CHANNEL (switch to channel):** >75dB below 20MHz, >55dB below 250MHz, and >60dB below 500MHz.

**ISOLATION (switch to switch):** >80dB below 20MHz, >70dB below 250MHz, and >60dB below 500MHz.

**MAXIMUM SIGNAL LEVEL:** 24V on Model 7062, 5V on Model 7063, switched; 50mA; 0.5 watt switched.

**CONTACT LIFE:** >10<sup>6</sup> closures cold switching; >10<sup>5</sup> closures at maximum signal levels.

**CONTACT RESISTANCE:** <math>2\Omega</math> input to output.

**CONTACT POTENTIAL:** <math>20\mu\text{V}</math>

### ACCESSORIES AVAILABLE

7051-2	BNC Male to BNC Male Cable, 2ft.
7051-5	BNC Male to BNC Male Cable, 5ft.
7051-10	BNC Male to BNC Male Cable, 10ft.

## Low Voltage Scanner Card

### 20-Channel

The Model 7064 has 20 channels and features <math>1\mu\text{V}</math> thermal offset. It will switch any one of twenty signals to one output or switch one signal to any one of twenty outputs. Switching is accomplished in less than 2ms. Expected relay life (10<sup>8</sup> closures) is obtained when signals less than 10V or 10mA are switched.

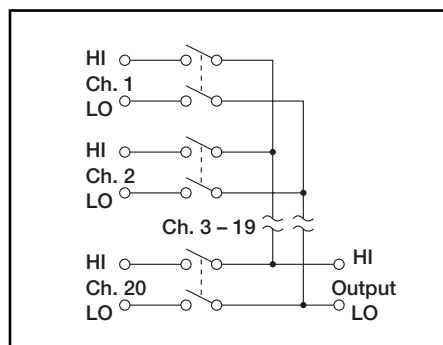

**CHANNELS PER CARD:** 20.

**CONTACT CONFIGURATION:** 2-pole Form A, common guard connection.

**CONNECTOR TYPE:** Screw terminal #18AWG maximum wire size.

**RELAY DRIVE CURRENT:** 14mA per relay typical.

**MAXIMUM SIGNAL LEVEL:** 40V, 100mA, or 2VA (resistive load only).

**CONTACT LIFE:** >10<sup>8</sup> closures cold switching; >10<sup>6</sup> closures at maximum signal levels.

**CONTACT RESISTANCE:** <math>2\Omega</math> to rated life.

**CONTACT POTENTIAL:** <math>1\mu\text{V}</math> differential voltage, input to output with copper leads (<math>200\text{nV}</math> typical within 1 minute of actuation).

**WARM-UP:** 1 hour in mainframe for thermal stability.

**ACTUATION TIME:** <math>2\text{ms}</math>, exclusive of mainframe.

**CHANNEL ISOLATION:** >10<sup>12</sup>, <math>10\text{pF}</math>

**INPUT ISOLATION, DIFFERENTIAL:** >10<sup>9</sup> $\Omega$ , <math>75\text{pF}</math>

**INPUT ISOLATION, COMMON MODE:** >10<sup>9</sup> $\Omega$ , <math>150\text{pF}</math>

**COMMON MODE VOLTAGE:** <math>100\text{V}</math> peak.

**OPERATING ENVIRONMENT:** 0° to 50°C, up to 35°C at 70% RH.

**STORAGE ENVIRONMENT:** -25°C to 65°C.

1.888.KEITHLEY (U.S. only)

[www.keithley.com](http://www.keithley.com)
**KEITHLEY**

A GREATER MEASURE OF CONFIDENCE