

# DAC-02

## 2-Channel Analog Output Board



- 2 analog output channels
- 12-bit resolution
- +5, +10,  $\pm 5$ ,  $\pm 10$ V output ranges
- 4–20mA current loop capability

### Ordering Information

DAC-02 2-Channel Analog Output Board with Software on CD-ROM

### Functional Description

The DAC-02 is ideal for controlling setpoints. It provides two independent double-buffered, 12-bit multiplying D/A channels plus interface circuitry. The D/A converters can be used with a fixed DC reference as conventional D/A. Onboard references of  $-5$ V and  $-10$ V provide output ranges of  $0-5$ V,  $0-10$ V,  $\pm 5$ V,  $\pm 10$ V and  $4-20$ mA for process control current loops. Alternatively, the D/A may be operated with a variable or AC reference signal as multiplying D/A; where the output is the product of reference and digital inputs. With an AC reference, the unipolar outputs provide two-quadrant multiplication and the bipolar outputs provide four-quadrant operation. Twelve-bit accuracy is maintained up to 1kHz.

Since data is represented in 12 bits, it is written to each D/A in two consecutive bytes. The first byte contains the four least significant bits of data. The second byte contains the most significant eight bits of data. The least significant byte is written first and is stored in an intermediate register in the D/A (having no effect on the output). When the most significant byte is written, its data is combined with the stored least significant data and presented to the D/A converter, thus assuring a single-step update. This process is known as double buffering.

The DAC-02 is a 5-inch-long half-slot board suitable for use in IBM PC/XT/AT and all compatibles. The DAC-02 is addressed as an I/O device using eight I/O locations and may have its I/O address set to any 8-bit boundary in the 255–1023 (decimal) I/O address space. The board uses the internal  $+5$ V,  $+12$ V, and  $-12$ V computer supplies.

### 4–20mA Current Loop Output

The 4–20mA current loop output consists of a precision current sink formed by a VMOS power FET and reverse protection diode.

A minimum voltage of 8V must be maintained across this output circuit to insure correct operation. The maximum voltage should not exceed 36 volts for power dissipation reasons. A 24V or 36V loop supply is ideal. There are two ways of connecting the process loop: grounded load with floating supply, or floating load with grounded supply. The second method allows many loops to be powered by the same supply, but constrains the load to be two-wire floating. The alternative connections are shown to the left.

### ACCESSORIES AVAILABLE

K1802	3.5 ft. Cable with Female DB25
STA-U	Universal Screw Terminal Accessory
TESTPOINT	TestPoint™ Software Package

### APPLICATIONS

- Servo control
- Programmable amplifier
- 12-bit resolution voltage source
- Function generator

Ideal for controlling setpoints

DATA ACQUISITION PRODUCTS

1.888.KEITHLEY (U.S. only)

[www.keithley.com](http://www.keithley.com)

KEITHLEY

A GREATER MEASURE OF CONFIDENCE

# DAC-02

# 2-Channel Analog Output Board

## Connector Pin Assignments

A rear view of the 25-pin D connector is shown at left. The DAC-02 board has a female DB25 socket, and a DB25P solder cup plug is required to make connections (Keithley part # SMC-25). Usually only three or four wires (D/A outputs and ground) will be required for connections, so that a multi-wire flat cable is not required. (Note: 25-pin D connectors are identical to RS-232C connectors.) Output range selection is controlled by jumpering pins on the I/O connector or on the STA-U screw terminal board.

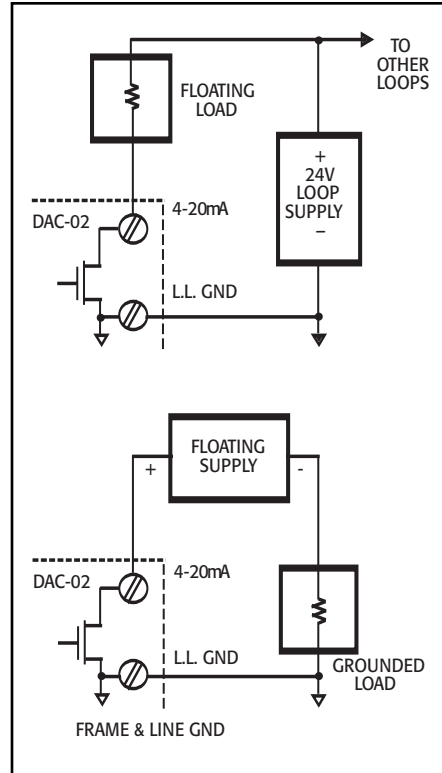
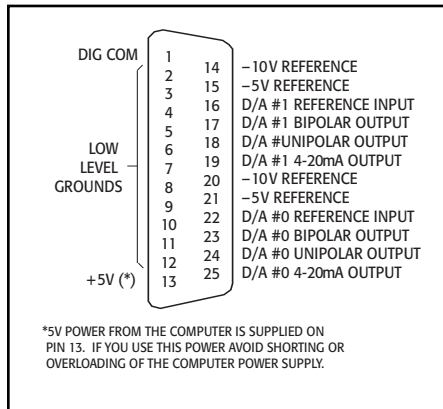

## SPECIFICATIONS

### OUTPUT RANGES

CHANNELS: 2.

I/O ADDRESS: DIP switch selected on any 8-bit boundary.

RESOLUTION: 12 bits (1 part in 4095).

RELATIVE ACCURACY: 1/2 LSB (0.01%) max.

DIFFERENTIAL LINEARITY: 1/2 LSB max.

FIXED REFERENCE RANGES: 0 to +5V (unipolar)  
0 to +10V (unipolar)  
±5V (bipolar)  
±10V (bipolar)  
4-20mA current loop.

VARIABLE REFERENCE RANGES: ±10V (2 or 4 quadrant).

REFERENCE INPUT RESISTANCE: 7kΩ min, 11kΩ typ, 20kΩ max.

VOLTAGE OUTPUT IMPEDANCE: <0.1Ω max.

VOLTAGE OUTPUT: ±5mA min drive current.

4-20 mA COMPLIANCE (FOR CURRENT LOOP): 8-36V.

SETTLING TIME: 150μs to 0.001% typ (for a full-scale step).

TEMPERATURE COEFFICIENT OF GAIN:

±25ppm/°C (with reference).

±5ppm/°C (external reference).

ZERO DRIFT: ±3ppm/°C.

### ENVIRONMENTAL

OPERATING TEMPERATURE: 0-70°C.

STORAGE TEMPERATURE: -55 to +125°C.

HUMIDITY: 0-95% non-condensing.

WEIGHT: 4oz (120g).

DIMENSIONS: 5in L × 4.25in H × 0.75in D (12.7cm × 10.8cm × 1.9cm).