

Repair Manual

**3.5 mm and Type-N
Slotless Contact**

For use with Slotless Repair Kits



Part Number 85052-90070

Printed in USA August 2001

Supersedes: December 1995

Notice

The information contained in this document is subject to change without notice.

Agilent Technologies makes no warranty of any kind with regard to this material, including, but not limited to, the implied warranties of merchantability and fitness for a particular purpose. Agilent Technologies shall not be liable for errors contained herein or for incidental or consequential damages in connection with the furnishing, performance or use of this material.

Agilent Technologies assumes no responsibility for the use or reliability of its software on equipment that is not furnished by Agilent Technologies.

This document contains proprietary information which is protected by copyright. All rights are reserved. No part of this document may be photocopied, reproduced, or translated to another language without prior written consent of Agilent Technologies.

RESTRICTED RIGHTS LEGEND

Use, duplication, or disclosure by the U.S. Government is subject to restrictions as set forth in subparagraph (c) (1) (ii) of the Rights in Technical Data and Computer Software clause at DFARS 252.227-7013 for DOD agencies, and subparagraphs (c) (1) and (c) (2) of the Commercial Computer Software Restricted Rights clause at FAR 52.227-19 for other agencies.

Agilent Technologies, Inc.
Santa Rosa Systems Division
1400 Fountaingrove Parkway
Santa Rosa, CA 95403-1799, U.S.A.

© Copyright 1995, 2001 Agilent Technologies. All Rights Reserved.
Reproduction, adaptation, or translation without prior written permission is prohibited, except as allowed under the copyright laws.
Santa Rosa Systems Division, 1400 Fountaingrove Pkwy, Santa Rosa, CA 95403-1799

Warranty

Certification *Agilent Technologies certifies that this product met its published specifications at the time of shipment from the factory. Agilent Technologies further certifies that its calibration measurements are traceable to the United States National Institute of Standards and Technology (NIST, formerly NBS), to the extent allowed by the Institute's calibration facility, and to the calibration facilities of other International Standards Organization members.*

Warranty This Agilent Technologies instrument product is warranted against defects in material and workmanship for a period of one year from date of delivery. During the warranty period, Agilent Technologies will, at its option, either repair or replace products which prove to be defective.

For warranty service or repair, this product must be returned to a service facility designated by Agilent Technologies. Buyer shall prepay shipping charges to Agilent Technologies and Agilent Technologies shall pay shipping charges to return the product to Buyer. However, Buyer shall pay all shipping charges, duties, and taxes for products returned to Agilent Technologies from another country.

Agilent Technologies warrants that its software and firmware designated by Agilent Technologies for use with an instrument will execute its programming instructions when properly installed on that instrument. Agilent Technologies does not warrant that the operation of the instrument, or software, or firmware will be uninterrupted or error free.

LIMITATION OF WARRANTY

The foregoing warranty shall not apply to defects resulting from improper or inadequate maintenance by Buyer, Buyer-supplied software or interfacing, unauthorized modification or misuse, operation outside of the environmental specifications for the product, or improper site preparation or maintenance.

NO OTHER WARRANTY IS EXPRESSED OR IMPLIED. AGILENT TECHNOLOGIES SPECIFICALLY DISCLAIMS THE IMPLIED WARRANTIES OF MERCHANTABILITY AND FITNESS FOR A PARTICULAR PURPOSE.

EXCLUSIVE REMEDIES

THE REMEDIES PROVIDED HEREIN ARE BUYER'S SOLE AND EXCLUSIVE REMEDIES. AGILENT TECHNOLOGIES SHALL NOT BE LIABLE FOR ANY DIRECT, INDIRECT, SPECIAL, INCIDENTAL, OR CONSEQUENTIAL DAMAGES, WHETHER BASED ON CONTRACT, TORT, OR ANY OTHER LEGAL THEORY.

Assistance *Product maintenance agreements and other customer assistance agreements are available for Agilent Technologies products. For any assistance, contact your nearest Agilent Technologies Sales and Service Office. Addresses are provided at the back of this manual.*

Contents

1. General Information	
Introduction	1-1
85052-60049	1-1
85054-60056	1-1
Equipment Required But Not Supplied	1-2
Incoming Inspection	1-2
Precision Slotless Connectors	1-2
Replaceable Parts	1-3
Ordering Parts	1-3
Replacing Documentation	1-3
2. Repairing A Slotless Contact	
Introduction	2-1
Inspecting A Damaged Slotless Contact	2-2
Removing A Slotless Contact	2-4
Step 1	2-4
Step 2	2-5
Step 3	2-6
Inspecting and Cleaning A Center Conductor	2-8
Inspecting	2-8
Cleaning	2-8
Inserting An Inner Contact	2-9
Testing A Slotless contact	2-11

Index

Figures

1-1. Replaceable Parts	1-5
2-1. Finger Bent In or Crushed	2-2
2-2. Broken Inner Contact	2-3
2-3. Inner Contact Pushed Inside	2-3
2-4. Damaged Center Conductor	2-3
2-5. The Inner Contact and Center Conductor	2-4
2-6. Inserting the Removal Tool	2-5
2-7. Moving a Damaged Finger	2-5
2-8. Freeing a Broken Contact Finger	2-6
2-9. Removing a Broken Contact Finger	2-6
2-10. Threading the Removal Tool Into the Inner Contact	2-7
2-11. Removing the Inner Contact	2-7
2-12. Damaged Center Conductor	2-8
2-13. How to Properly Hold the Inner Contact	2-9
2-14. Installing a New Inner Contact	2-10
2-15. Inspecting the Installation	2-10
2-16. Inserting the Testing Tool	2-11
2-17. Testing the Retention Force of the Contact	2-12

Tables

1-1. Replaceable Parts	1-4
2-1. Contacting Agilent	2-13

General Information

Introduction

This manual documents the use of both the 85052-60049 and the 85054-60056 slotless contact repair kits. Each kit contains the following:

- One 30 ml bottle of alcohol
- Six foam swabs
- One pair of tweezers
- One inner contact removal tool
- One inner contact insertion tool
- One inner contact testing tool
- One testing weight
- Ten replacement inner contacts

An explanation of precision slotless connectors appears later in this chapter under “Precision Slotless Connectors.”

The following Agilent Technologies publication provides information on proper connector care to maintain quality standards and devices:

- Microwave Connector Care Card (included in this kit).

Or, contact your nearest Agilent Technologies sales office for the customer training course:

“Understanding Connectors Used With Network Analyzers.”

- 85050A +24A (on site)
- 85050A +24D (at Agilent Technologies sales office)

85052-60049 Use the 3.5 mm slotless contact repair kit to repair the female contacts on all 3.5 mm precision slotless connectors (PSC). The only exception to this is the precision slotless contacts in the airlines of the 85052C 3.5 mm precision calibration kit. If damaged, these contacts must be repaired at the factory.

85054-60056 Use the Type-N slotless contact repair kit to repair the female contacts on all Type-N precision slotless connectors (PSC).

Note

There is no similar contact repair kit for 2.4 mm connectors. The 2.4 mm slotless contact is an integral part of the center conductor and it cannot be replaced.

Equipment Required But Not Supplied

The following items are required, but not supplied with this kit:

- A microscope with $\geq x10$ magnification and lighting.
- A source of clean, dry, compressed air or nitrogen.

Incoming Inspection

Refer to Table 1-1 to verify receipt of all parts in this repair kit.

The foam-lined storage case provides protection for the components in this repair kit during shipping. If the case or components appear damaged, set aside the kit and all packaging materials and contact the nearest Agilent Technologies office listed at the back of this manual.

If either of the following conditions exist, notify your nearest Agilent Technologies office:

- The shipping contents are incomplete.
- There is mechanical damage or a mechanical defect.

Notify the carrier if the shipping container is damaged or the cushioning material shows signs of stress. Keep all shipping material for the carrier's inspection. Agilent Technologies will arrange for repair or replacement of incomplete or damaged shipments without waiting for a settlement from the transportation company.

Precision Slotless Connectors

When properly used, a precision slotless connector should have the same lifespan as a standard slotted connector. Agilent Technologies designed the precision slotless contacts to mate with all connectors within a connector series, but the connectors must meet published interface dimensions.

CAUTION

Mating a connector that does not meet published specifications can damage a precision slotless connector. For this reason, ensure that any device you connect is within its specifications.

Replaceable Parts

Ordering Parts

Table 1-1 lists replacement part numbers. To order a listed part, note the description, part number, and the quantity desired. Telephone or send your order to the nearest Agilent Technologies office (listed at the back of this manual).

Replacing Documentation

The part number for this manual is listed on the title page of this document, and is also listed in Table 1-1. Use this number to order extra copies of this manual.

Table 1-1. Replaceable Parts

Reference Number	Description	Qty	Part Number
1	Isopropyl Alcohol	1	8500-5344
2	Foam Swab	6	9301-1243
3	Tweezers	1	8710-1308
4	Removal Tool 3.5 mm Type-N	1	5021-7602 5021-7607
5	Insertion Tool 3.5 mm Type-N	1	5022-0509 5022-0510
6	Testing Tool 3.5 mm Type-N	1	5022-0508 5022-0511
7	Testing Weight	1	5022-0507
8 ¹	Inner Contacts 3.5 mm Type-N	10	85052-60050 85054-60057
8 ²	Inner Contacts 3.5 mm Type-N	1	85052-60051 85054-60058
	Storage Case	1	
	Wooden Box	1	9211-1582
	Foam in Lid	1	5180-8457
	Foam in Bottom	1	5181-5730
	Documentation	1	
	Repair Manual		85052-90070
	Connector Care Card		08510-90360
	Complete Repair Kit 3.5 mm Type-N	1	85052-60049 85054-60056

1 Same parts as 85052-60051 and 85054-60058 but different quantity.

2 Same parts as 85052-60050 and 85054-60057 but different quantity.

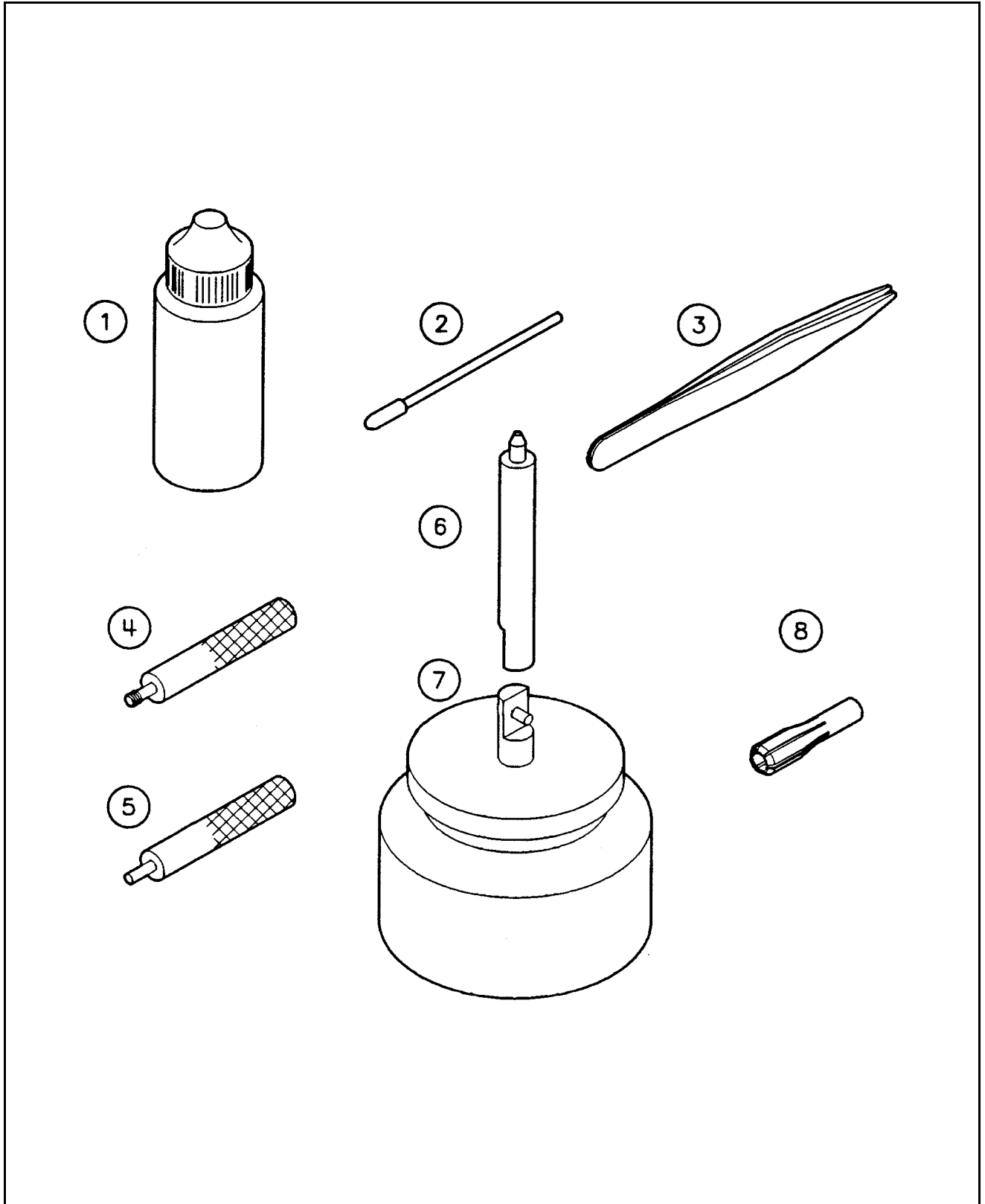

Figure 1-1. Replaceable Parts

Repairing A Slotless Contact

Introduction

If you suspect a problem with the slotless contact, make a visual inspection to determine if there is damage. As you use a connector, dirt and metal particles can accumulate in and around the slotless contact. In extreme cases this accumulation can render the contact non-functional. Often, simply cleaning the contact fixes the problem.

This chapter provides procedures on how to clean both the inner contact and the center conductor, how to reinstall the inner contact, and how to test for functionality. Also provided is a procedure on how to replace the inner contact.

Repairing a damaged slotless contact is a six-step process:

1. Gage the connector. Because connector mechanical tolerances can be very precise (on the order of a few hundredths of micrometers), even a perfectly clean, unused connector can cause trouble if it is mechanically out of specification. If the pin depth is out of specification, the connector is damaged beyond the capabilities of this repair kit, and the device must be repaired or replaced by Agilent Technologies.

CAUTION

Never use an out-of-specification connector.

2. Under $\geq 10\times$ magnification, inspect the connector to determine the damage.
3. Remove the damaged inner contact.
4. Inspect the center conductor. If it is undamaged, clean it.
5. Install the replacement inner contact.
6. Test the slotless contact.

Inspecting A Damaged Slotless Contact

Inspect the contact under $\geq x10$ magnification to define the problem. Usually you can make the repair without disassembling the device to which the precision slotless contact is attached.

Inspect the slotless contact to see if any of the following conditions exist:

- The inner contact has one or more fingers bent inward or crushed, preventing proper contact to the male pin (see Figure 2-1).
- If so, go to step 1 of “Removing A Slotless Contact.”
- The inner contact has one or more fingers broken (see Figure 2-2).

If so, go to step 2 of “Removing A Slotless Contact.”

- The inner contact is pushed inside the center conductor and will not make contact with the mating connector’s male pin (see Figure 2-3).

If so, go to step 3 of “Removing A Slotless Contact.”

- The end of the center conductor is dented or scraped near where it touches the inner contact (see Figure 2-4).

If so, the slotless contact may be damaged beyond the capabilities of this repair kit, and the device must be repaired or replaced by Agilent Technologies.

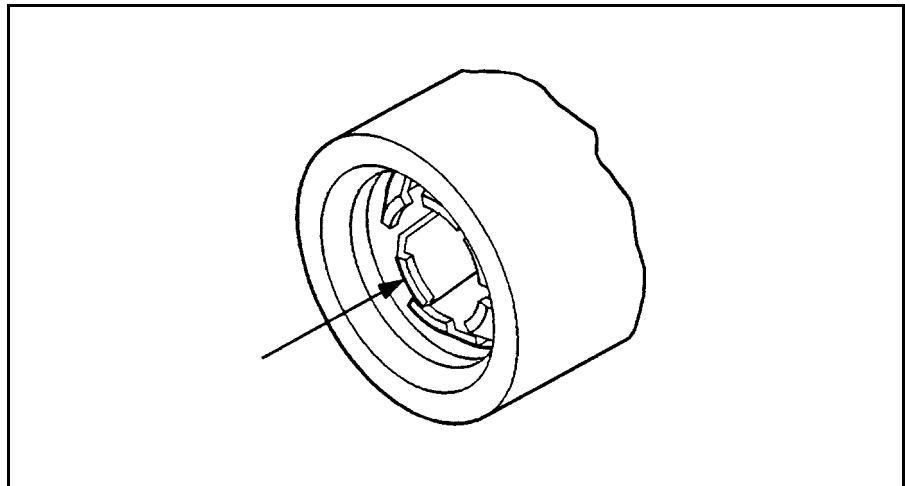

Figure 2-1. Finger Bent In or Crushed

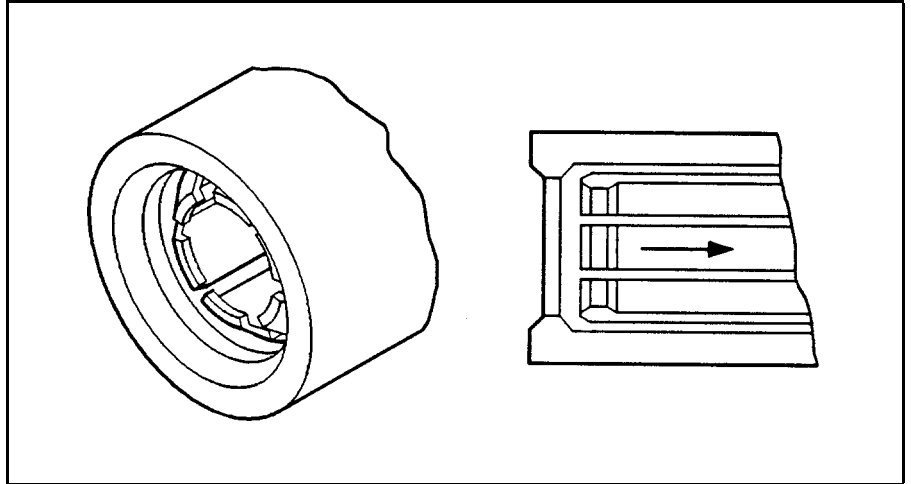

Figure 2-2. Broken Inner Contact

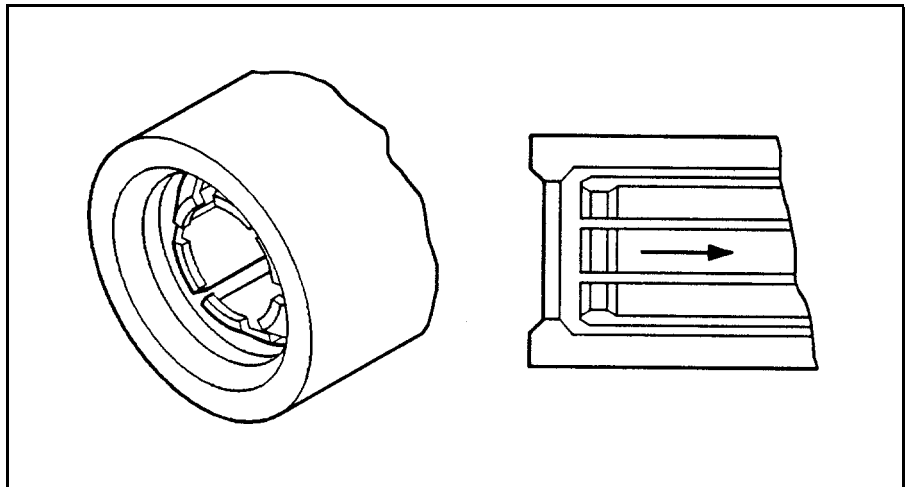

Figure 2-3. Inner Contact Pushed Inside

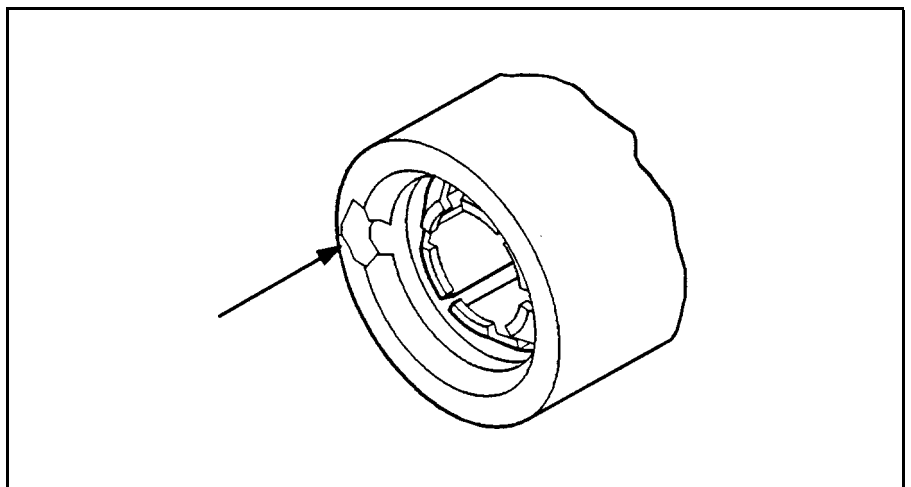

Figure 2-4. Damaged Center Conductor

Removing A Slotless Contact

- Step 1** If one or more of the inner contact's fingers are bent inward or crushed, you must straighten or remove those fingers before you remove the entire inner contact. Figure 2-5 shows both the inner contact and the center conductor.

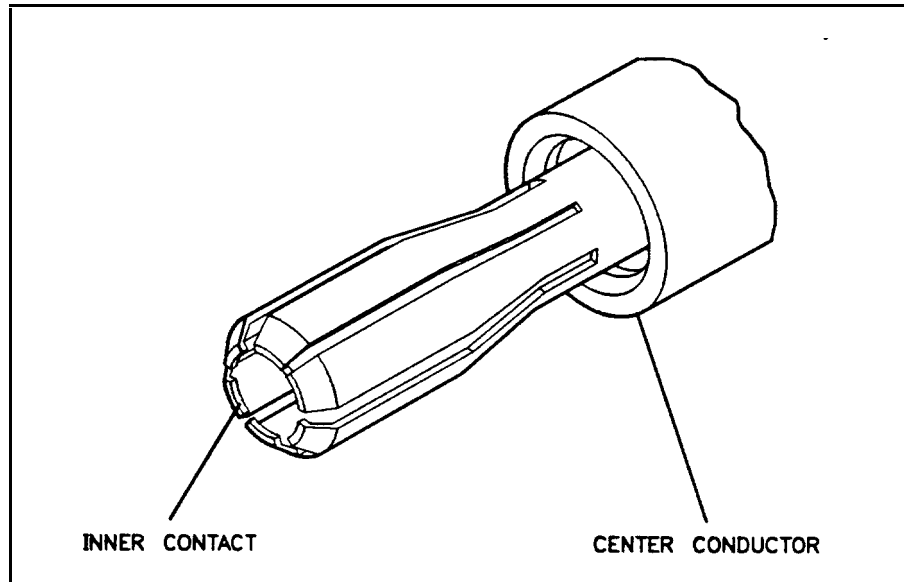

Figure 2-5. The Inner Contact and Center Conductor

- a. Under magnification, carefully try to insert the removal tool (see Figure 2-6).
- b. If the damaged fingers prevent you from inserting the tool, use the tweezers provided to either move aside or remove the damaged fingers (see Figure 2-7).

CAUTION

Avoid damaging the center conductor, which houses the inner contact. Do not touch the tweezers to anything but the damaged inner contact. Do not, under any circumstances, use anything to squeeze or clamp on to the center conductor that might cause damage.

- c. After you move or remove the damaged inner contact fingers and can insert the inner contact removal tool, go to step 3.

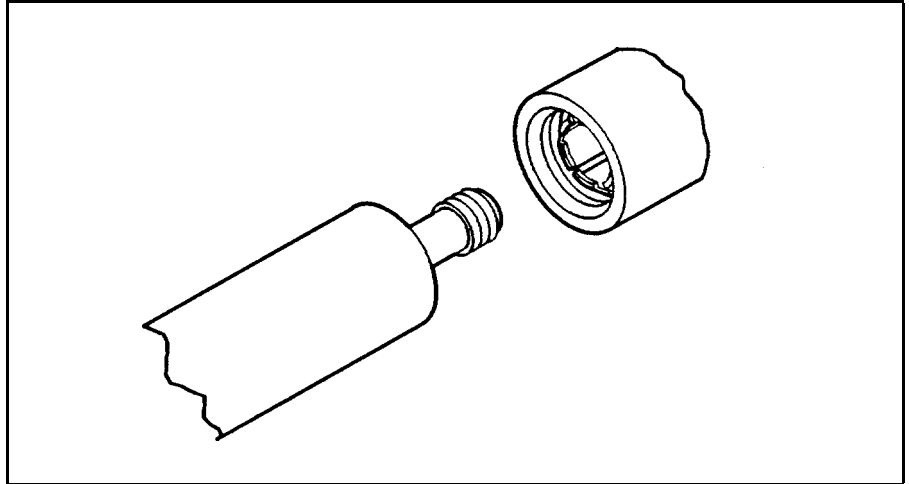

Figure 2-6. Inserting the Removal Tool

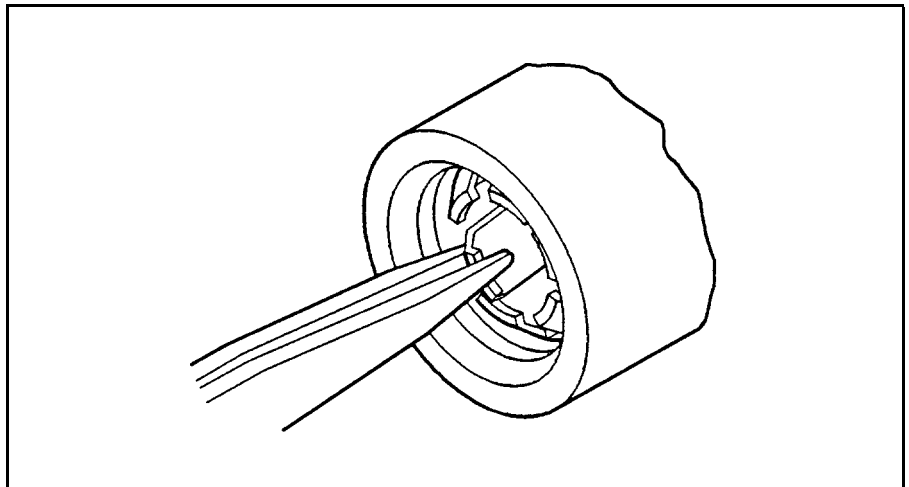

Figure 2-7. Moving a Damaged Finger

Step 2

If one or more of the inner contact's fingers are broken, you must remove that finger before you remove the entire inner contact:

- a. Under magnification, look down inside the inner contact and locate the broken finger or fingers.

The fingers may have already fallen out. If so, continue with step 3.

- b. If you can see the broken fingers inside the inner contact, turn the device upside down and gently tap on it (see Figure 2-8).

Using this gentle tapping, try to force the broken fingers to drop out or at least move forward far enough so that you can remove them with the tweezers (see Figure 2-9). Do not, under any circumstances, use anything other than gentle tapping.

- c. After you remove the broken inner contact fingers and can carefully insert the inner contact removal tool, go to step 3.

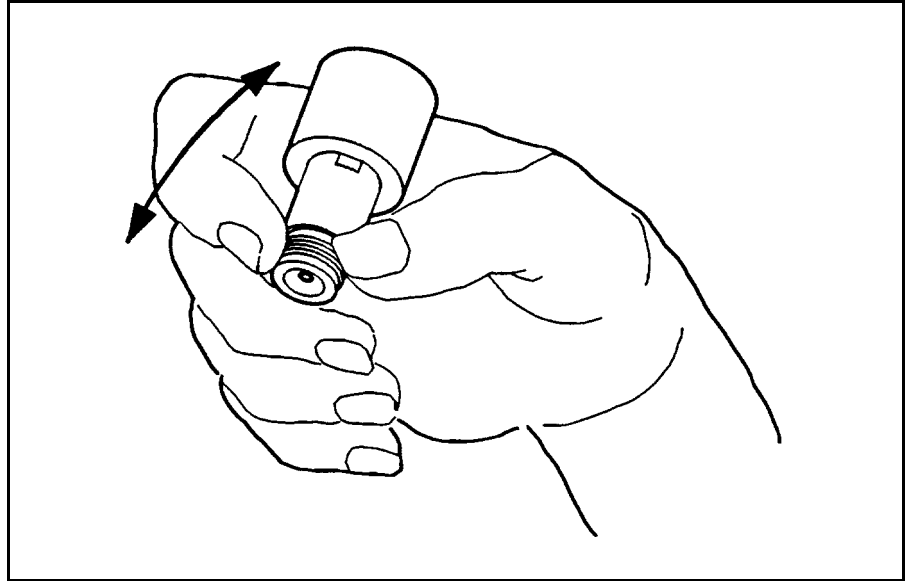

Figure 2-8. Freeing a Broken Contact Finger

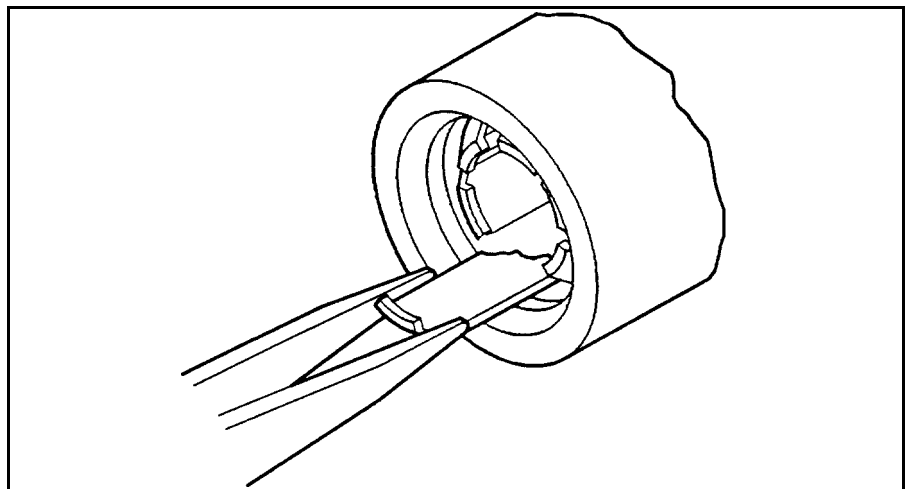

Figure 2-9. Removing a Broken Contact Finger

- Step 3** If the inner contact is pushed inward and no longer makes contact with the mating connector's male pin, you must remove and replace the inner contact:
- a. Under magnification, insert the removal tool into the damaged contact far enough so that it touches the bottom of the inside of the inner contact.
 - b. Turn the tool clockwise to engage the tool coupling thread with the thread on the inside of the contact (see Figure 2-10).
 - c. Occasionally the inner contact spins with the tool, preventing the tool from engaging. If this happens, apply a small amount axial pressure to the tool and continue to turn it clockwise.

- d. Once the tool is engaged by 2 turns, you can remove the inner contact. Pull the tool and inner contact straight out away from the center conductor (see Figure 2-11).

CAUTION

Do not damage the center conductor as you remove the inner contact.

- e. Unthread the broken inner contact from the removal tool and discard the contact; it cannot be repaired or reused.

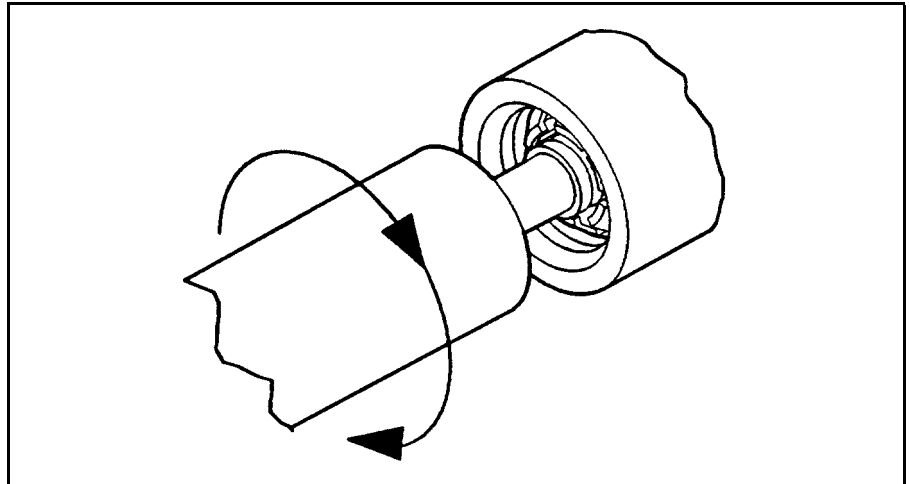

Figure 2-10. Threading the Removal Tool Into the Inner Contact

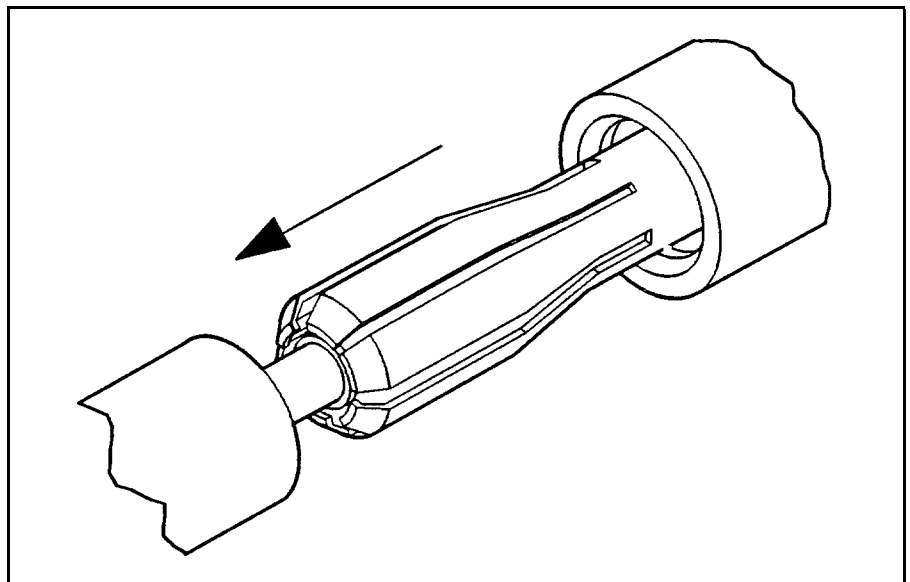

Figure 2-11. Removing the Inner Contact

Inspecting and Cleaning A Center Conductor

Inspecting

1. Under magnification, inspect the center conductor for damage.
2. Refer to Figure 2-12. Is the center conductor gouged? Does it have any imperfection that would interfere with the insertion of a new inner contact? If so, you must return the device to Agilent Technologies for repair; you cannot repair a center conductor with this kit.
3. If the center conductor is undamaged, or if the damage is too light to affect device performance, clean the center conductor.

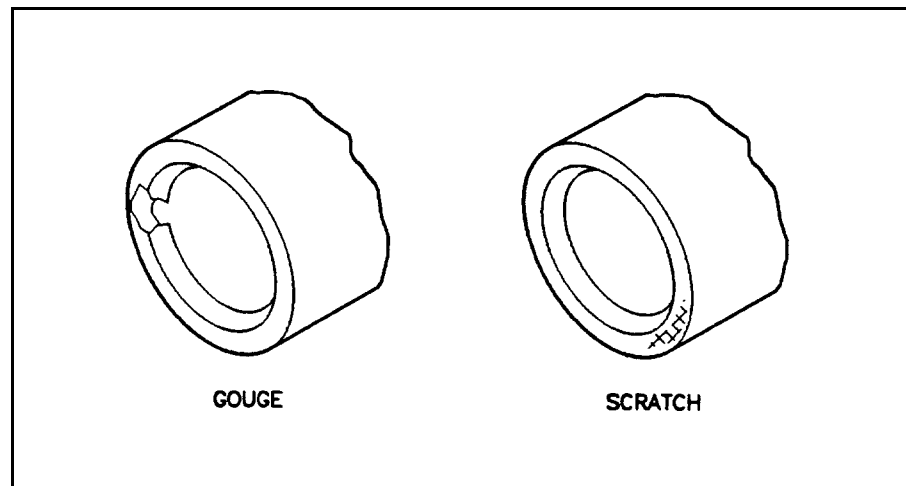

Figure 2-12. Damaged Center Conductor

Cleaning

1. Under magnification, look for loose dirt or metal particles.
2. Using the foam swabs and isopropyl alcohol provided in this repair kit, clean the center conductor.
3. Using a source of dry air or nitrogen, blow out the hole in the center conductor; be sure that all the alcohol evaporates.
4. The clean center conductor is now ready for you to insert a new inner contact.

Inserting An Inner Contact

When you install a replacement inner contact, be careful handling the replacement parts. These parts are fragile until they are inside the center conductor; do not squeeze or misuse them in any way.

1. Using the tweezers provided in this kit, carefully pick up a new inner contact by its small-diameter end (away from the fingers, see Figure 2-13). Do not use excessive pressure. Holding the contact by the fingers will damage it.

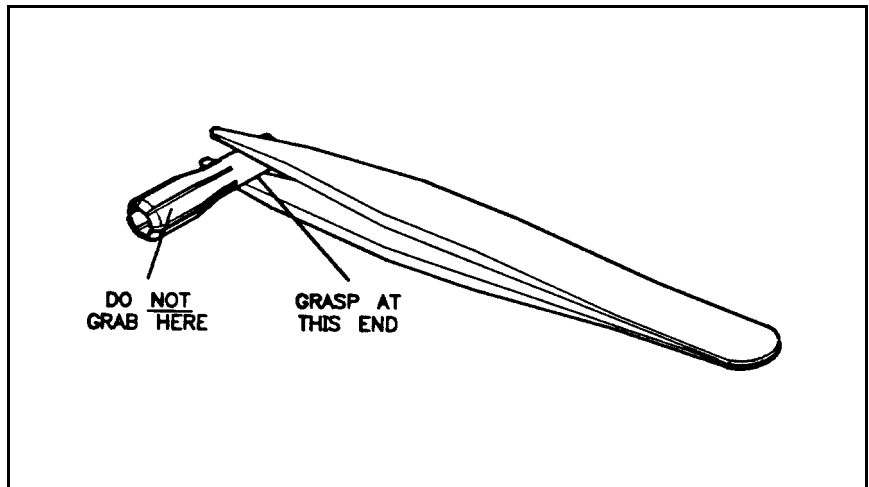

Figure 2-13. How to Properly Hold the Inner Contact

2. Under magnification, carefully insert the insertion tool into the new inner contact until it hits bottom. Do not use the removal tool (with the threaded end) to insert the inner contact, or you may damage the new inner contact.
3. Let go of the contact with tweezers and slowly insert the contact into the center conductor (see Figure 2-14). As you install the contact, its fingers compress and the force required to insert it first increases and then decreases. When the insertion force begins to decrease, do not push too hard or you may damage the new inner contact or center conductor.
4. At the point that the contact snaps into place, stop pushing.
5. Carefully withdraw the insertion tool from the inner contact.
6. Under magnification, visually inspect the assembly and make sure the inner contact is properly installed (see Figure 2-15).

CAUTION

Never apply either lubricant or adhesive to an inner contact.

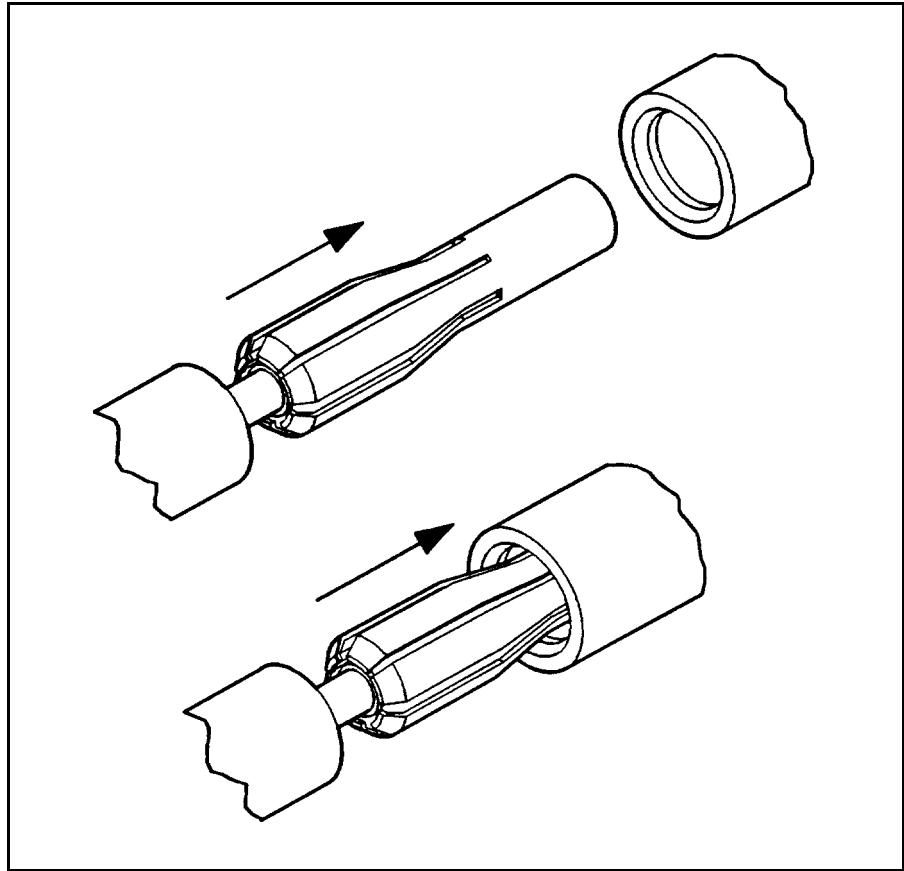

Figure 2-14. Installing a New Inner Contact

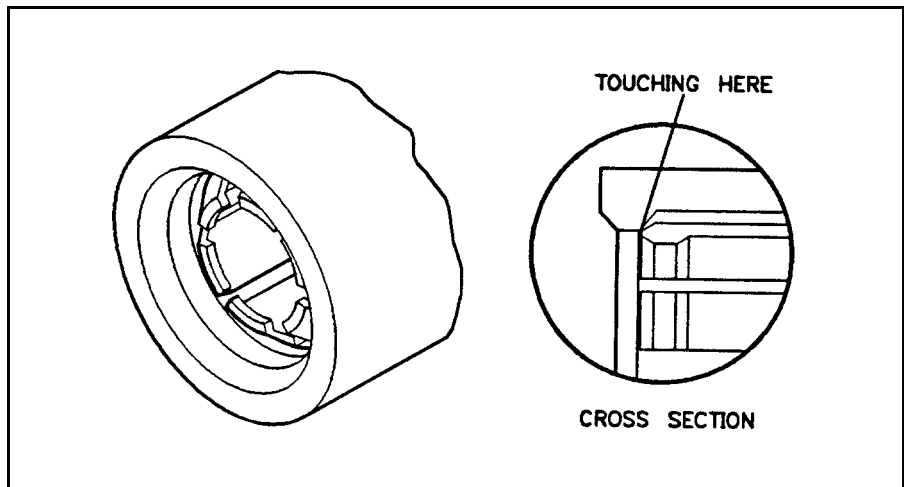

Figure 2-15. Inspecting the Installation

Testing A Slotless contact

After you install a new inner contact, you must test it using the tools provided in this repair kit. This tool was designed to help find improperly installed inner contacts.

1. Using a foam swab and alcohol, clean the testing tool.
2. Under magnification, carefully install the testing tool in the slotless contact assembly (see Figure 2-16).
3. Repeat step 2, two more times.
4. Inspect the inner contact. If the fingers are damaged, remove and replace the inner contact.
5. Insert the testing tool.
6. With the testing tool inserted, turn the device upside down so that the testing tool hangs by the grip of the slotless contact.
7. Hook the testing weight to the testing tool. If the contact has the proper minimum retention force, it does not lose its grip.
8. Remove the testing weight.
9. Remove the testing tool.
10. Visually inspect the slotless contact.
11. If you see any dirt or metal particles, clean the contact using the alcohol and foam swabs provided in this kit.
12. The clean, precision slotless connector is ready for use.

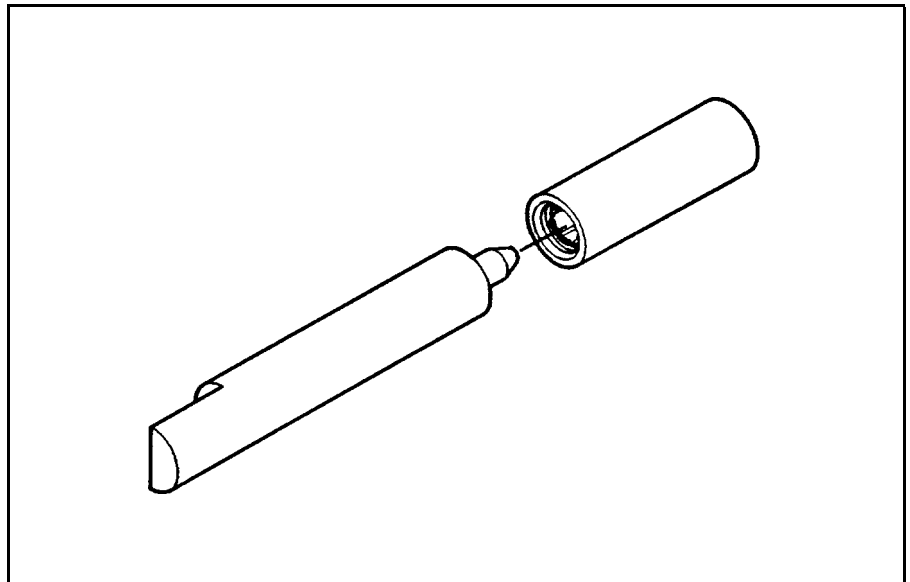

Figure 2-16. Inserting the Testing Tool

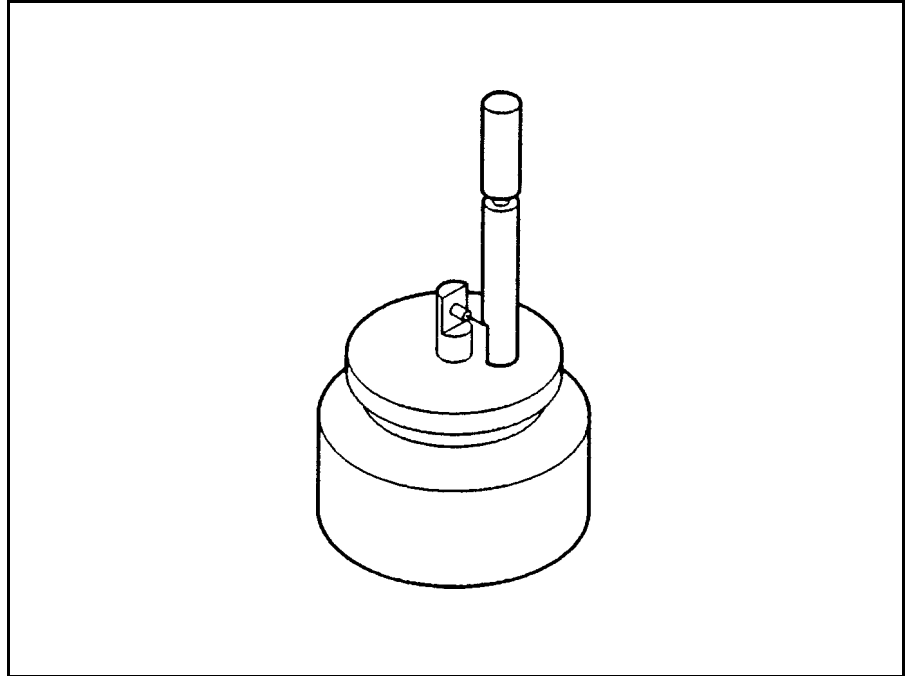

Figure 2-17. Testing the Retention Force of the Contact

By internet, phone, or fax, get assistance with all your test & measurement needs.

Table 2-1. Contacting Agilent

Online Assistance: www.agilent.com/find/assist

United States (tel) 1 800 452 4844	Japan (tel) (81) 426 56 7832 (fax) (81) 426 56 7840	New Zealand (tel) 0 800 738 378 (fax) 64 4 495 8950
Canada (tel) 1 877 894 4414 (fax) (905) 206 4120	Latin America (tel) (305) 269 7500 (fax) (305) 269 7599	Asia Pacific (tel) (852) 3197 7777 (fax) (852) 2506 9284
Europe (tel) (31 20) 547 2323 (fax) (31 20) 547 2390	Australia (tel) 1 800 629 485 (fax) (61 3) 9210 5947	

