

# UNIQUELY POWERFUL



**LabMaster 10 Zi-A**  
20 GHz – 65 GHz Oscilloscopes

# More channels, faster analysis



The most powerful high bandwidth oscilloscope available powers through complex calculations faster:

- Up to 80 channels using ChannelSync™ architecture
- Powerful 24-core server-class CPU
- Up to 192 GB of RAM available

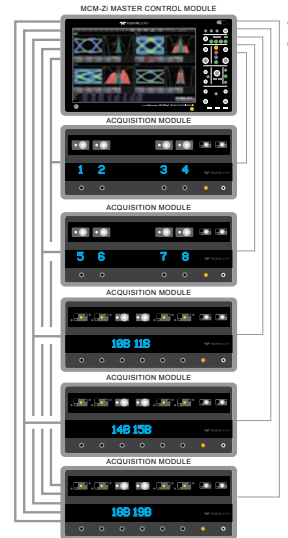

# Best for Serial Data & DDR



Unmatched high-speed serial tools

- Simple and powerful compliance test automation
- Most complete serial data analysis toolset
- Fastest DDR Test Journey



# Analyze the Whole Link at Once

End-to-end link signal integrity analysis

- Import S-parameter files from WavePulser® 40iX and other instruments
- De-embed fixtures, emulate channels, apply transmitter/receiver equalization
- Debug with CrossSync™ PHY protocol and electrical cross-layer analysis

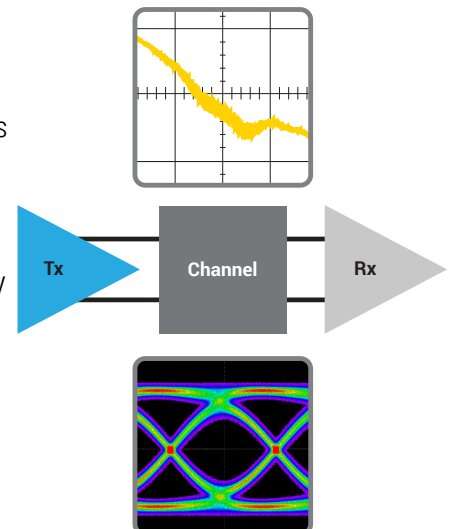



# Uniquely Powerful



80ch

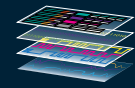

## High Bandwidth, Uniquely Powerful



# LabMaster 10 Zi-A

# MORE OSCILLOSCOPE CHANNELS, FASTER ANALYSIS



**LabMaster 10 Zi-A oscilloscopes can be configured with more channels than any other oscilloscope (up to 80 at up to 36 GHz, or up to 40 at up to 65 GHz). The Master Control Module contains a powerful server-class CPU configurable with up to 192 GB of RAM to more quickly perform the most complex calculations.**

## **Up to 80 Oscilloscope Channels**

LabMaster is the only high-bandwidth oscilloscope with the unique ChannelSync architecture for precise timing synchronization by design - channel to channel jitter is only 130 fs. LabMaster greatly simplifies greater than 4 channel oscilloscope setups and provides acquisition confidence.

## **Powerful 24-core Server-class CPU**

LabMaster has the most powerful CPU in any oscilloscope - an Intel® Xeon® Gold 6240R 24-core server-class CPU (or better). LabMaster plows quickly and easily through complex calculations, such as PCI Express® receiver calibration routines. Serial data jitter and eye diagram analysis goes faster with LabMaster.

## **Up to 192 GB of RAM Available**

LabMaster's powerful CPU is augmented with an enormous amount of available system RAM to ensure that long memory calculations are handled with ease.



# BEST OSCILLOSCOPE FOR SERIAL DATA AND DDR

The LabMaster 10 Zi-A is the best oscilloscope platform for high-speed serial data and advanced memory compliance and debug. The combination of more channels, mixed-signal options, serial decoders, and comprehensive compliance, analysis and debug software options puts you in the drivers seat.

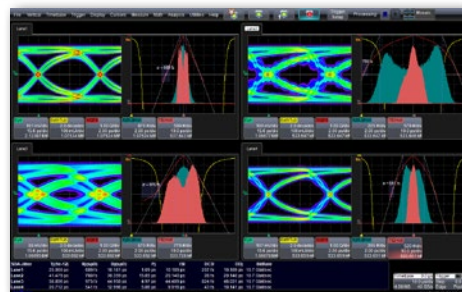
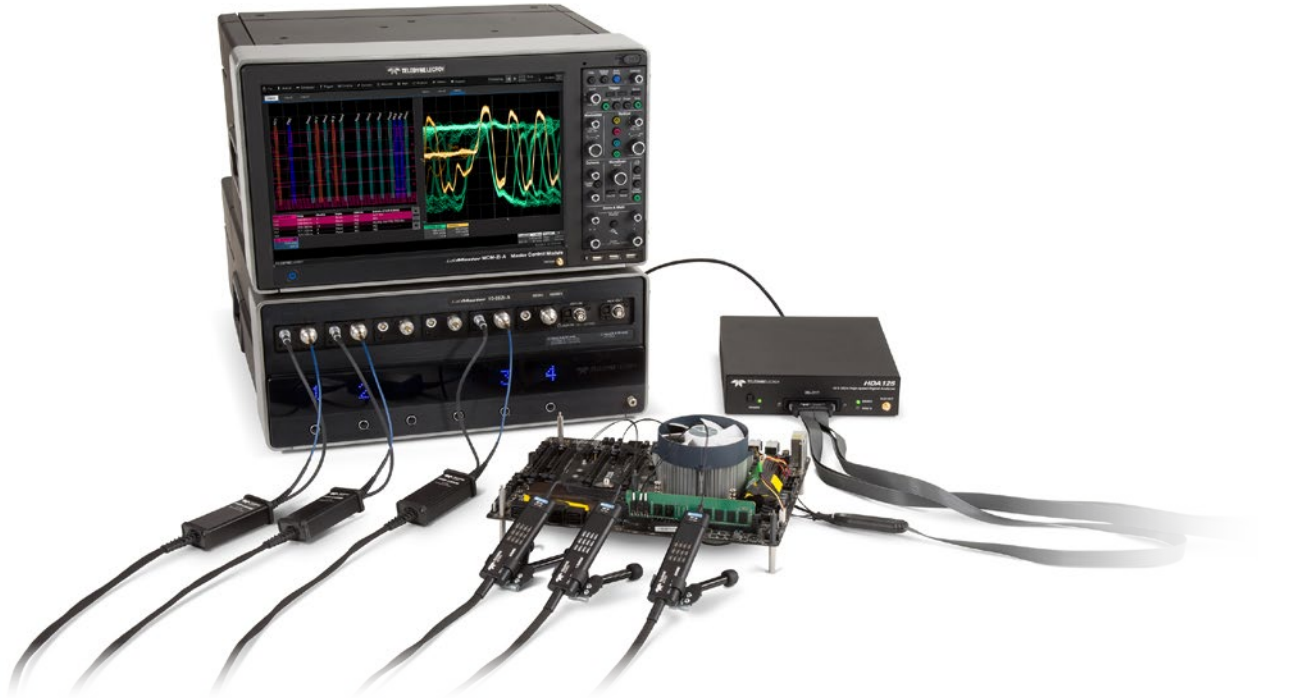

## Simple and Powerful Compliance Test Automation

- QualiPHY® automation software supports PCI Express®, USB®, HDMI®, DisplayPort™, DDR, and many other serial data standards
- Fully automated transmitter and receiver testing and fastest receiver test calibration
- Step-by-step instructions and automatic report generation
- Automated pass/fail test reports

## Most Complete Serial Data Analysis Toolset

- Multi-lane jitter and eye analysis
- LaneScape™ comparison modes
- Vertical noise and crosstalk analysis
- NRZ and PAM support
- Integrated equalization, emulation and de-embedding
- Virtual probing

## Fastest DDR Test Journey

- Maximize turn-on through validation
- Accelerate pre-compliance and fine-tuning
- QualiPHY automated compliance testing
- DDR5 software bundle (QualiPHY & Debug)
- Multi-scenario Views - eye, mask, measurements in each view
- External MSO "HDA125" - decode/trigger and R/W separation

# ANALYZE THE WHOLE LINK

Combining the WavePulser® 40iX High-speed Interconnect Analyzer, LabMaster 10 Zi-A oscilloscope and SDAIII-CompleteLinQ option gives the most complete signal integrity analysis toolkit available. Quickly characterize the entire signal path from transmitter to receiver, acquire high-fidelity waveforms at a convenient test point, and then easily analyze the signal at any point of interest.

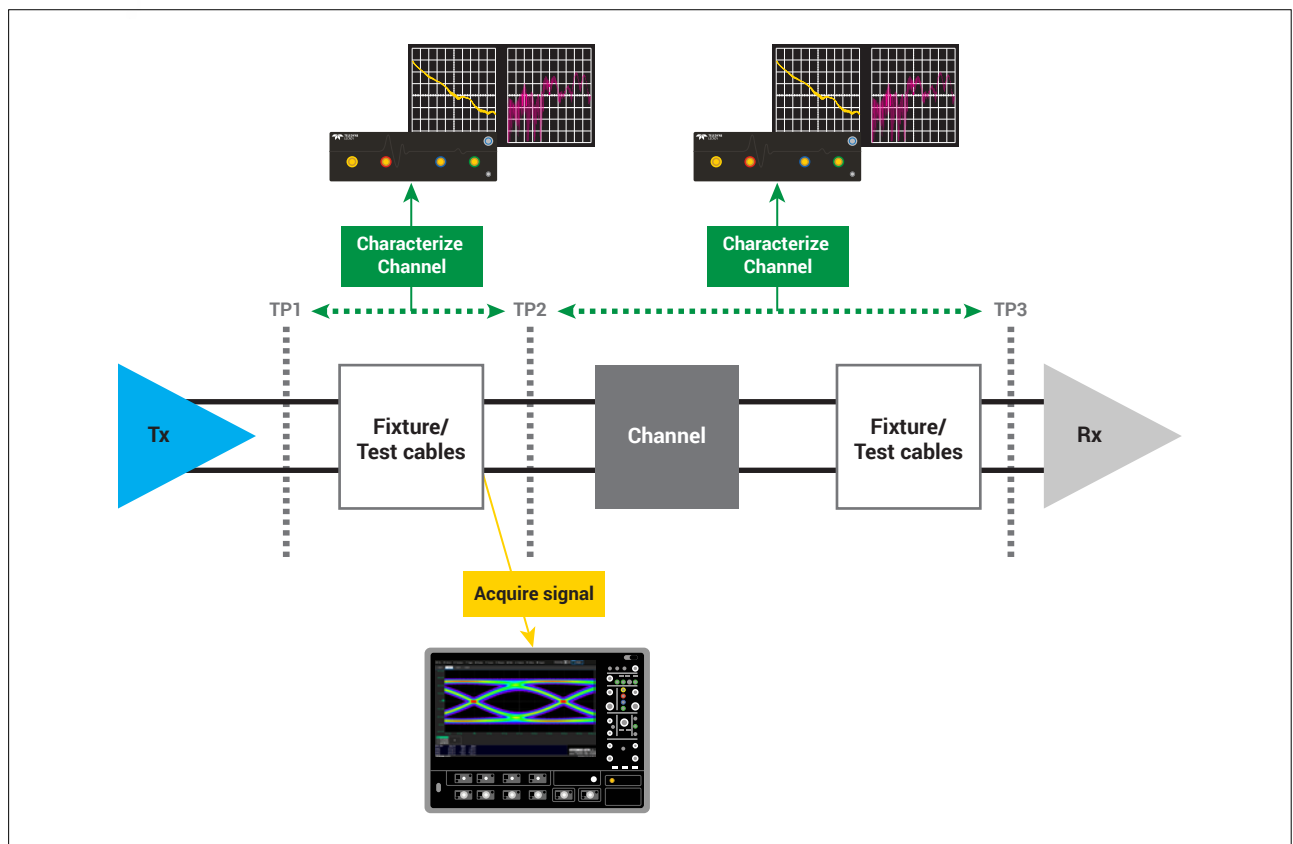
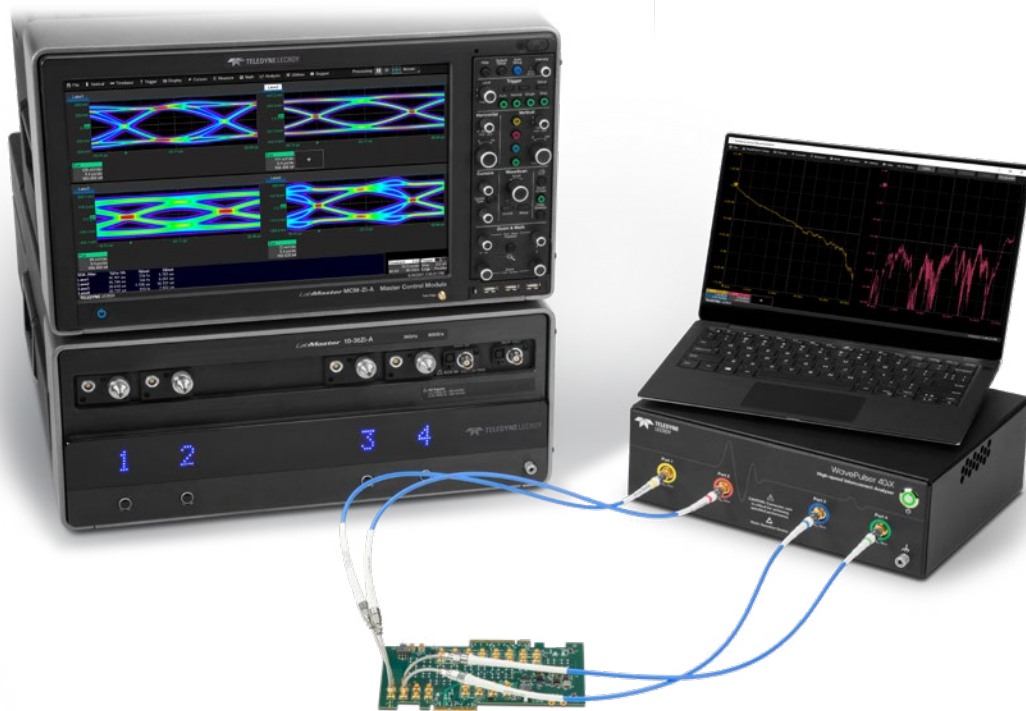

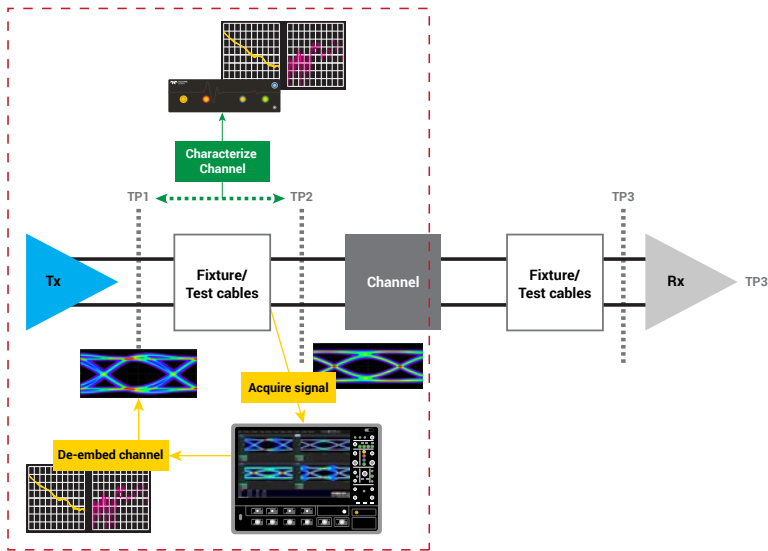

## De-embed fixtures and test cables

- Measure S-parameter models using WavePulser 40iX, or import from other measurements or simulation tools
- Sophisticated Eye Doctor and VirtualProbe tools easily and accurately remove effects of fixtures and cables from acquired oscilloscope waveforms
- Apply the full SDAIII-CompleteLinQ toolkit to de-embedded waveforms for full eye, jitter and noise analysis directly at the output pins of the device under test

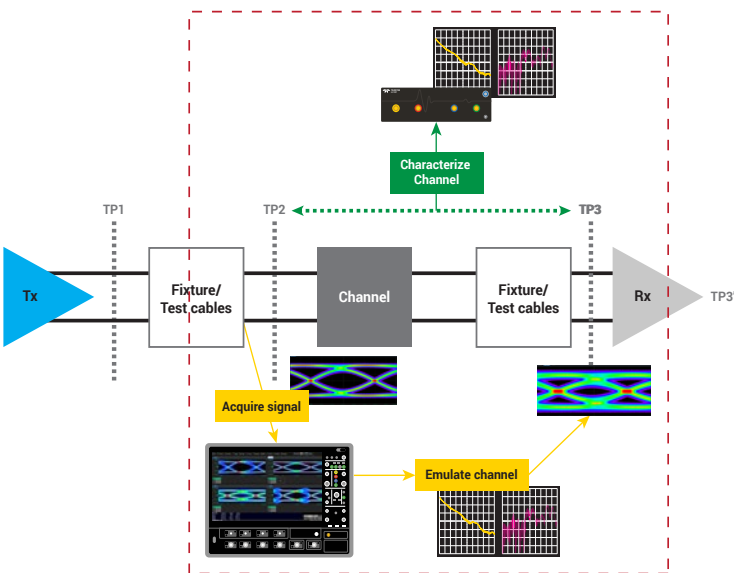

## Emulate real-world channel losses

- WavePulser 40iX simplifies and speeds up accurate measurements of test channel loss profiles
- Channel model s-parameter files can be easily imported from the WavePulser 40iX or elsewhere into Eye Doctor and VirtualProbe tools in the oscilloscope
- Acquire waveforms at any point in the signal path, then use VirtualProbe to cleanly embed the effects of the channel
- Use the full analysis capability of SDAIII-CompleteLinQ to compare eye, jitter and noise measurements at multiple test points simultaneously

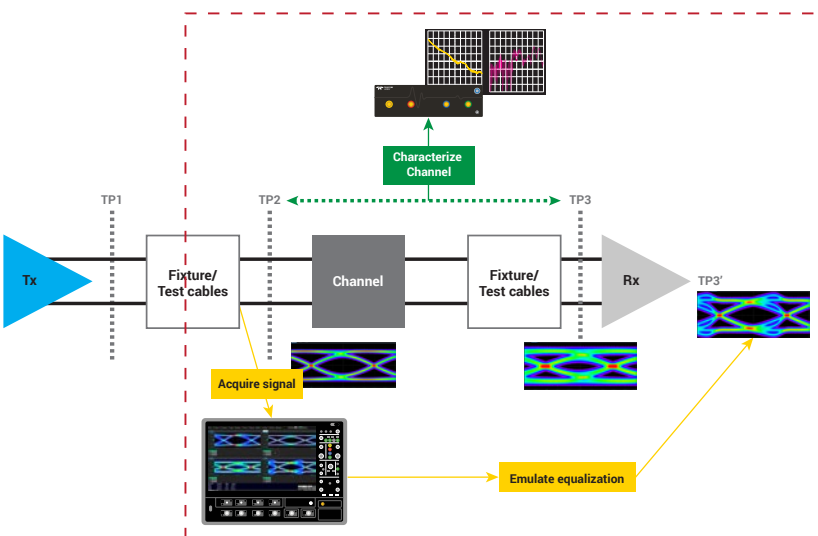

## Emulate transmitter and receiver equalization

- SDAIII-CompleteLinQ with Eye Doctor enables the emulation of all common equalization types, including:
  - Transmitter emphasis
  - Receiver FFE
  - Receiver CTLE
  - Receiver DFE

# SDAIII-COMPLETELINQ

The SDAIII software option provides the most comprehensive jitter decomposition, eye diagram and analysis tools with advanced signal integrity tools for emulation, de-embedding and equalization simulation.

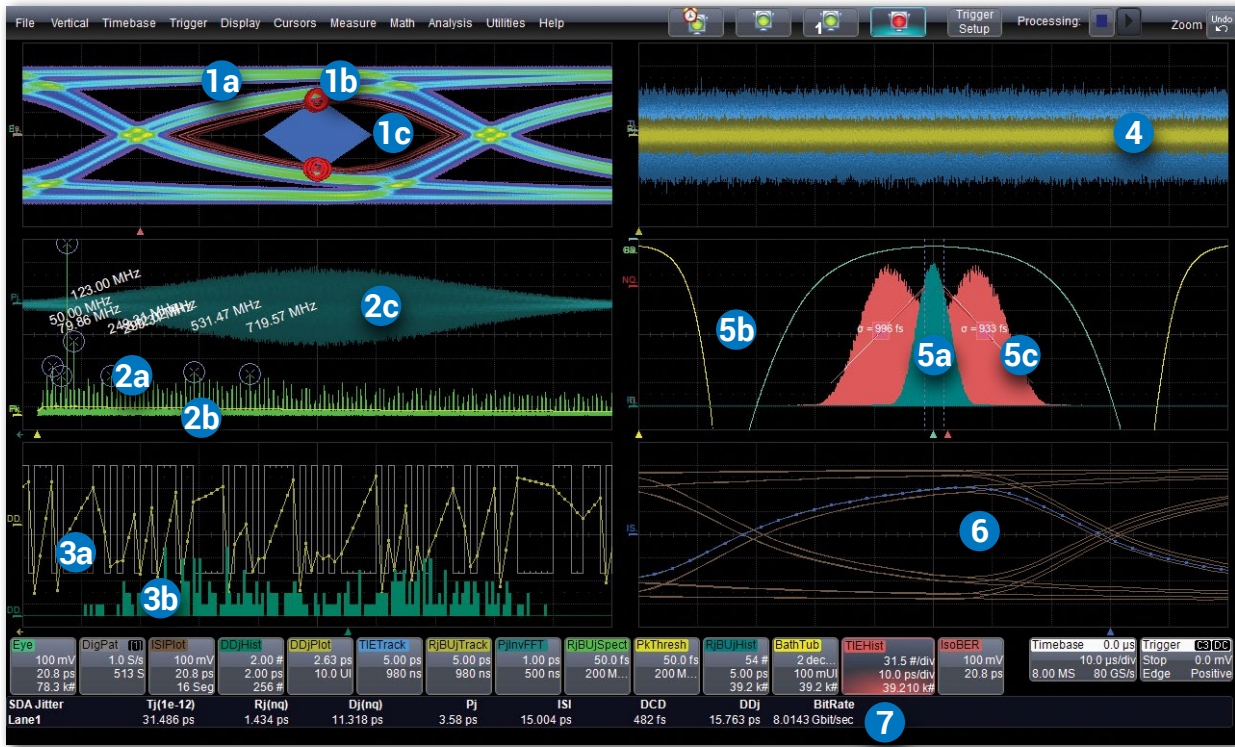

## Key Attributes

1. Eye diagram (a), eye mask failure (b) and IsoBER eye opening analysis (c)
2. Jitter spectrum (a) with noise floor display (b) and inverse FFT of the periodic jitter (c)
3. Data dependent jitter (DDJ) plot for each bit in synch with pattern (a) and with histogram (b)
4. Time interval error (TIE) jitter track analysis
5. Jitter histograms (a) with bathtub curves (b) and CDF plot (c)
6. Intersymbol interference (ISI) plots pinpoint bit sequences that have high ISI and are sources of bit errors
7. Jitter measurements table with full details for one or more "lanes" plus reference

## Advanced Signal Integrity Tools

Complete set of tools for: channel emulation; fixture, cable or channel de-embedding/embedding; adding or removing emphasis; performing CTLE, FFE or DFE equalization.

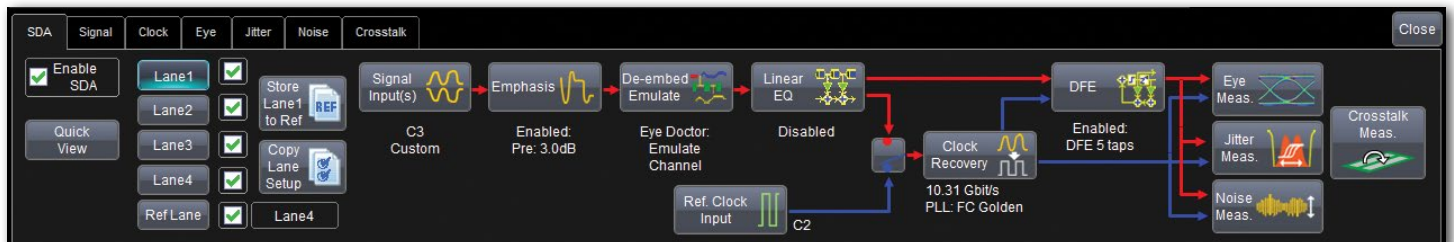



# COMPREHENSIVE SERIAL DATA ANALYSIS



Use the unique crosstalk eye to view and compare noise in a way that cannot be done with a traditional eye diagram.

## Fast Single or Multiple Eye Diagrams

- Up to four real-time and one reference comparison eye diagram, NRZ or PAM
- Single lane with multiple-point or multi-configuration analysis
- Analyze multiple lanes simultaneously
- Fast eye diagram creation
- Reference lane simplifies multi-scenario testing
- IsoBER displays expected eye infringement to a user-settable bit error rate (BER)
- Crosstalk eye contour plots display the impact of excessive noise

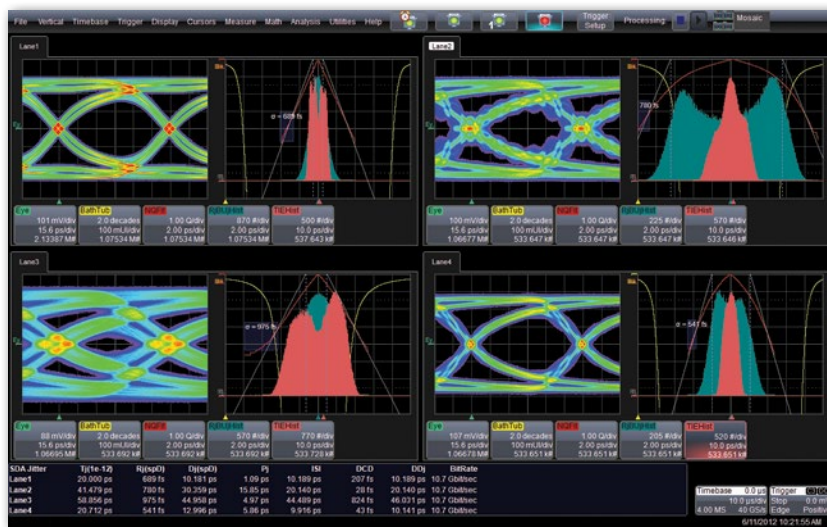

A comprehensive set of jitter measurements, extrapolations and decompositions, with associated views for complete understanding, provides the best capability to debug problems faster.

## Comprehensive Jitter Decomposition & Analysis

- Complete Tj, Rj and Dj decomposition numerics on up to four lanes/configurations plus a reference, NRZ or PAM
- Three different jitter decomposition models
- Complete random (Rj) and non-data dependent jitter (Rj+BUj) parameters and views
- Comprehensive data dependent jitter (DDj) analysis, including DDj plots and histograms, digital pattern display, and ISI plot by pattern
- Periodic jitter (Pj) inverse FFT
- Other jitter parameters including bounded uncorrelated jitter (BUj) and odd-even jitter (OEj)

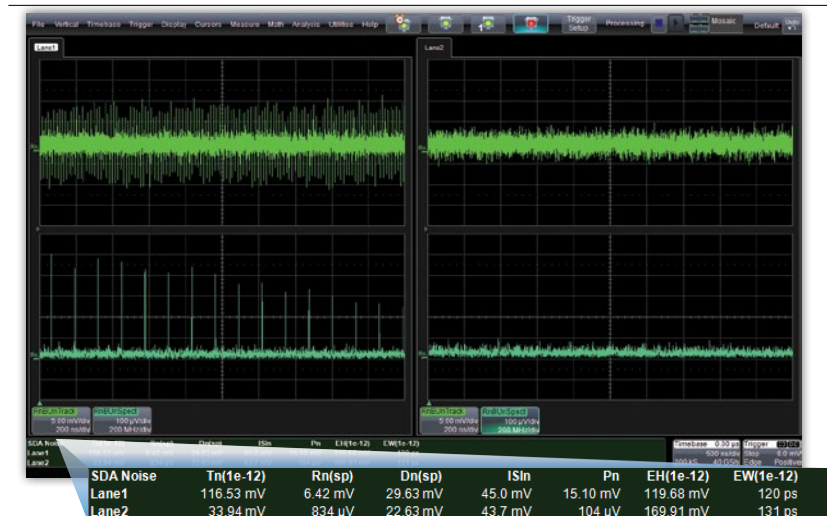

View noise measurements in both time and frequency domains for insight into sources of crosstalk leading to bit errors.

## Vertical Noise & Crosstalk Analysis

- Tools for complete aggressor/victim analysis
- Measure, extrapolate and decompose vertical noise just as you do with (horizontal) jitter
- Noise tracks, histograms and spectrums providing deep insight into noise sources
- Crosstalk eye contour plot shows probabilistic extent of noise, both inside and outside the eye

# FASTEST DDR TEST JOURNEY

The DDR test journey can be quick when the right tools for engineers enable smooth transitions from all stages of design, DDR turn-on, initial validation testing to fine-tuning, optimizing, pre-compliance and final compliance. Accelerate testing by confidently testing designs quickly and easily. Teledyne LeCroy covers BGA testing tools for JEDEC standards such as DDR2/3/3L/4/5 and LPDDR2/3/4/4X.

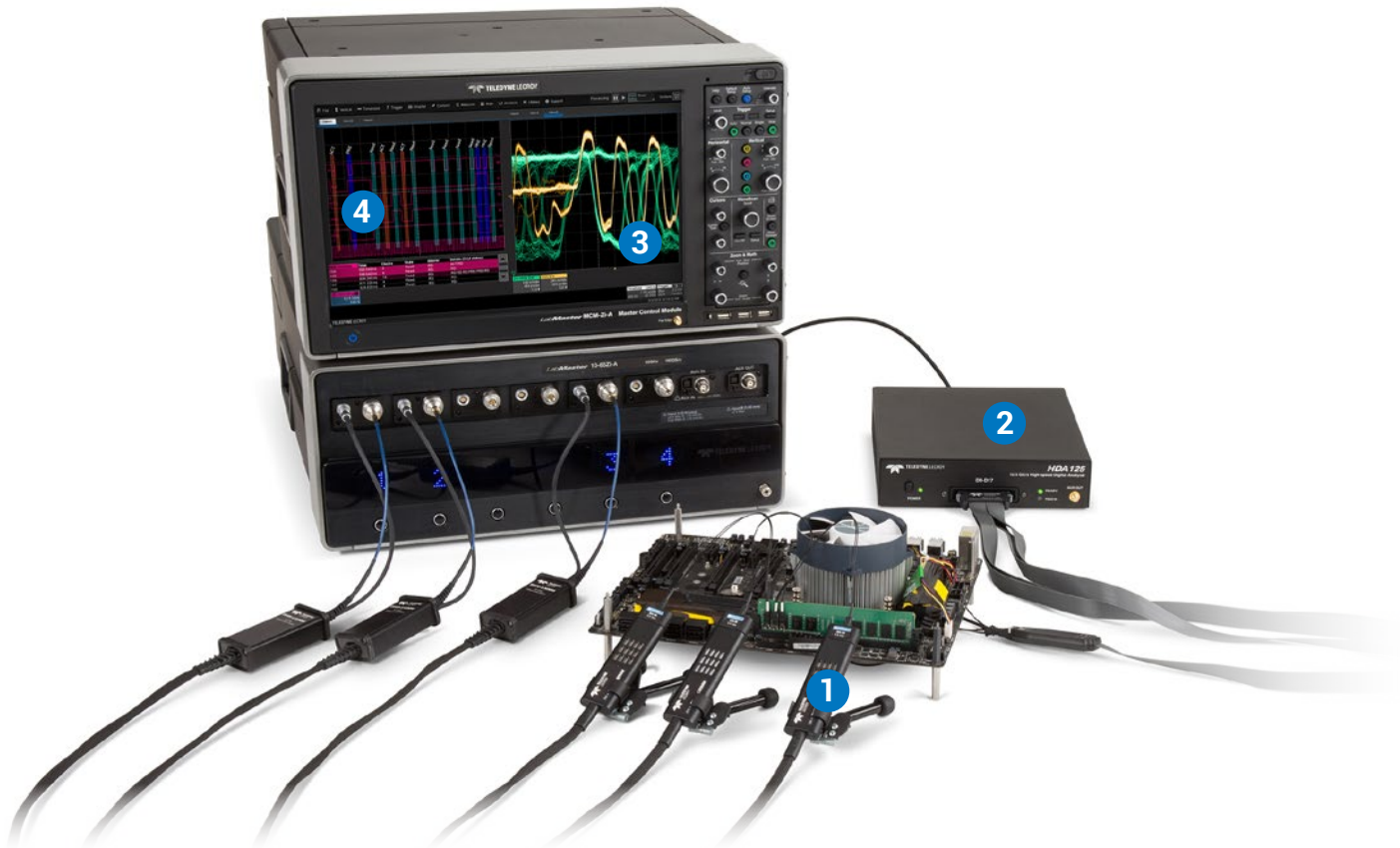

## 1. Interposers and Probes

- Interposers from reliable partners (Nexus and EyeKnowHow)
- High bandwidth probes with solder-in tips

## 2. External MSO - HDA125 “Logic Analyzer”

- Market’s only trigger & decode up to DDR5
- Validate 20+ Command Address packets
- Highest accuracy for Read/Write separation

## 3. Tools for Turn-on Through Pre-compliance

- Multi-scenario viewing fast-tracks testing
- Exclusive toolkit with JEDEC defined measurements
- Eliminate signal quality errors with virtual probing

## 4. Automated DDR5 Compliance Testing

- Measure the latest JEDEC specification at the BGA
- Increase repeatability & test consistency
- Save Pass/Fail reports with annotated screenshots

# DDR5 BUNDLE INCLUDES QUALIPHY & DEBUG TOOLKIT

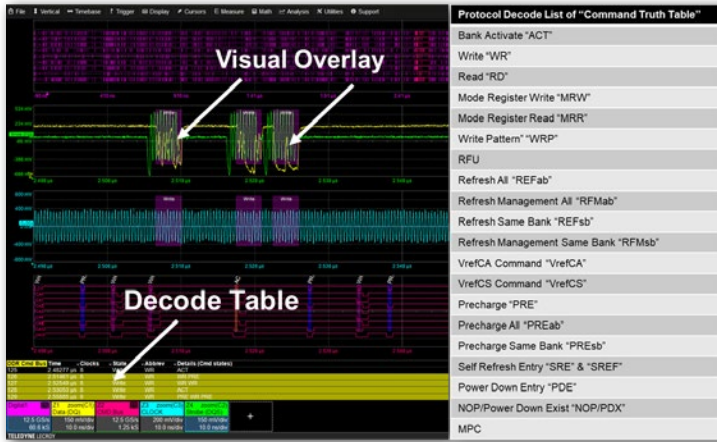

## Decode and Trigger

Establishing basic operation, signal checks and responses is the foundation of board turn-ons. Decode the command bus to understand if it's correctly communicating and know if Read and Write packets are present.

- Industry's only decode & trigger up to DDR5
- Decode 20+ packets from JEDEC Command Truth Table
- Perform better R/W separation using the command bus
- Overlay Read/Write visuals on channels
- Trigger on six different bus packet types

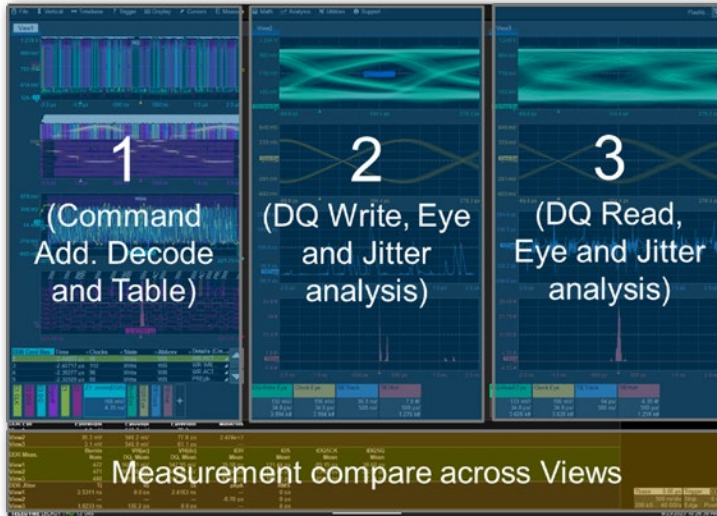

## Multiple Scenario Viewing Areas

DDR stability occurs when the DRAM has been fine-tuned and optimized. This occurs when the voltage and timing parameters have been adjusted and measured for peak performance.

- Fast-track tuning stages with unique comparisons
- Interactively perform eye diagram, mask and JEDEC specific measurements on each view
- High-speed external MSO (HDA125) enables the highest accuracy for Read & Write packet separation.

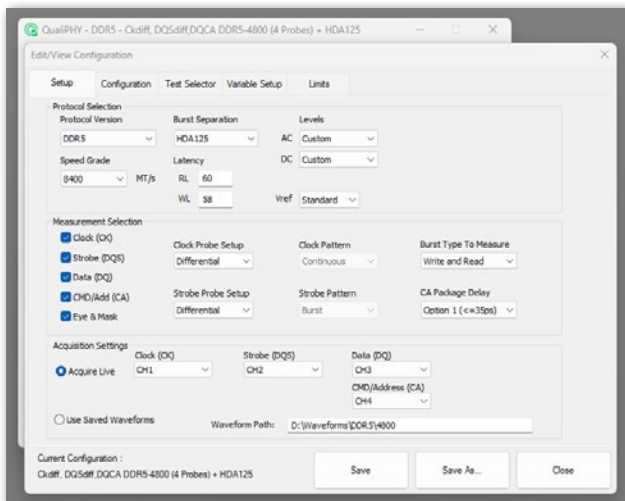

## Automated Compliance Testing

QualiPHY automated compliance testing enables faster test times by reducing inconsistencies, testing to the JEDEC standard and allows users to quickly stop and root-cause failures with the DDR Debug Toolkit.

- DDR5 JEDEC measurements for DQ, DQS, CK, CA signals
- Supports System Level testing at the BGA
- Save Pass/Fail reports with annotated screenshots.
- Analyze compliance failures in a dedicated Debug Toolkit



# COMPLETE PCI EXPRESS® ELECTRICAL TEST SOLUTIONS

Teledyne LeCroy's PCI Express electrical test solutions combine superior instruments with sophisticated jitter, eye diagram, debug and compliance software for all versions of PCI Express.

- Automated Transmitter, Receiver and Link Equalization (LEQ) testing with QualiPHY software options
- Visibility from physical layer through protocol operations
- LabMaster 10 Zi-A is gold suite certified for all relevant PCI Express 5.0 tests
- LabMaster 10 Zi-A supports PCI Express 6.0 test with PAM4 capabilities

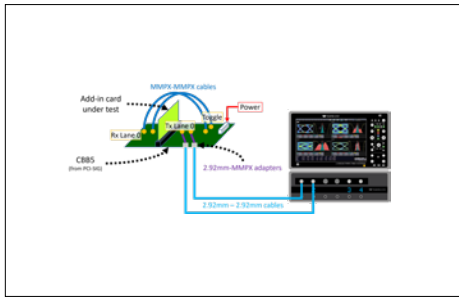

## Transmitter (Tx) Testing

- Base specification and compliance testing for add-in cards and systems in CEM, M.2 and U.2 form factors
- QualiPHY fully automates collection and processing of transmitter waveforms
- Supports TF-PCIE4-CTRL controller for full fixture and DUT automation
- Debug electrical compliance issues faster with SDAIII-CompletelinQ software

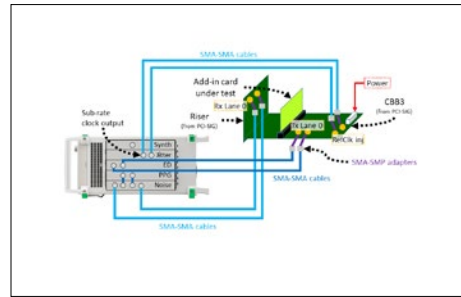

## Receiver (Rx) Testing

- Receiver calibration and testing using the LabMaster and Anritsu MP1900A BERT
- QualiPHY controls both the LabMaster and MP1900A
- Use WavePulser 40ix for receiver channel characterization and calibration
- Single QualiPHY user interface for Tx and Rx testing

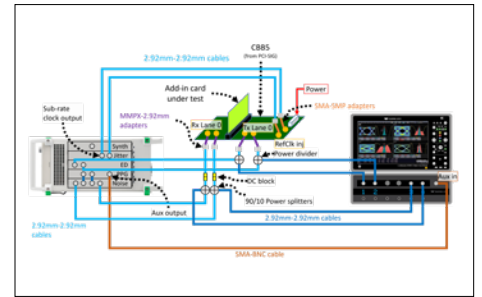

## Link Equalization (LEQ) Testing

- Fully automated Tx and Rx LEQ testing using QualiPHY with SigTest integration
- Test, fixture and DUT automation for fast throughput without lots of manual steps
- Go directly from compliance test to cross-layer debug using ProtoSync on the LabMaster and LTSSM analysis on the MP1900A
- Link the LabMaster with a protocol analyzer using CrossSync™ PHY for even deeper interoperability debug



## Superior PCIe® Test Solutions

- Approved PCI-SIG® gold suite solution for PCIe electrical compliance test programs
- High accuracy and repeatability due to superior signal quality
- Fastest receiver test calibration
- Complete DUT and fixture automation

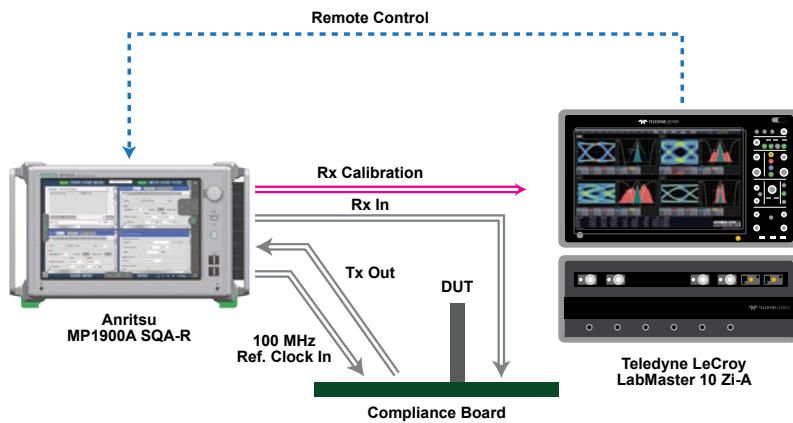

## Visibility from Physical Layer Through Protocol Operations

- LTSSM logging and state-machine triggering
- ProtoSync integrates industry-standard protocol display and physical-layer analysis
- Go directly from Link Equalization compliance tests to deep debug

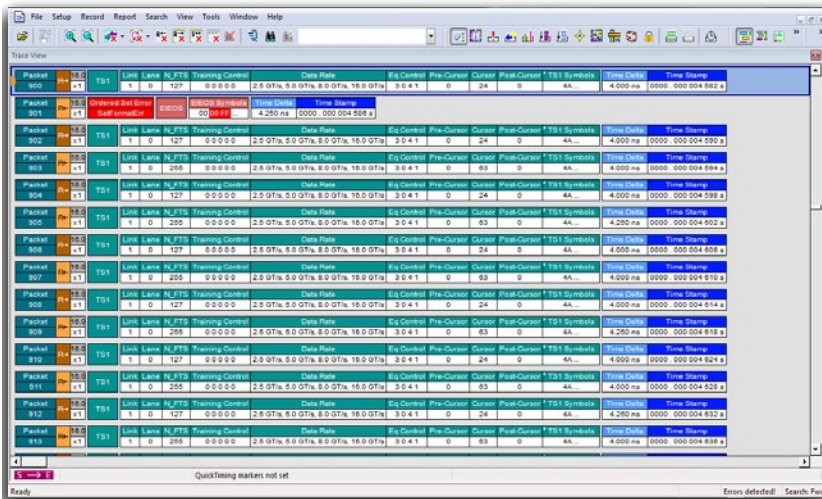

## Comprehensive PCI Express 6.0 Characterization Tools

- Unique transmitter equalization tools
- Highest confidence jitter measurements with PAM4 eye diagrams
- Most complete SNDR analysis



Interoperability issues can lead to finger-pointing exercises that cost money and time-to-market. Teledyne LeCroy CrossSync PHY software and interposers merge the functions of your Teledyne LeCroy PCI Express protocol analyzer and oscilloscope - giving insight into link behavior that no other instrument can provide.

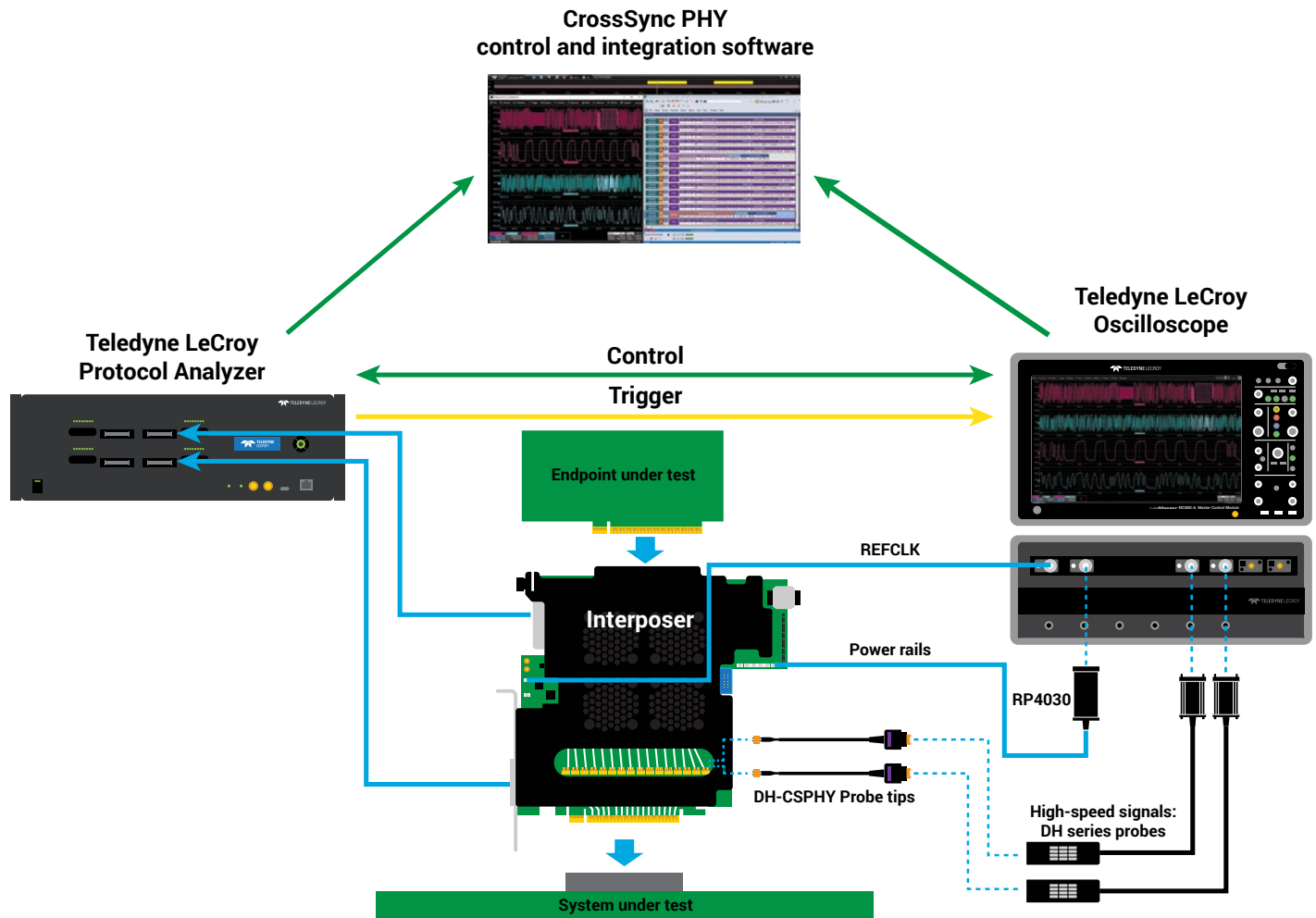

## Validate and debug active link operation

- CrossSync PHY capable interposers enable observation of both electrical and protocol behavior without disturbing the link
- Sideband signals, reference clock and power rails are all easily accessible to oscilloscope probes
- Optional high-bandwidth oscilloscope probing points for PCI Express data lanes

## Quickly resolve interoperability issues by capturing the entire protocol stack

- Trigger protocol analyzer and oscilloscope captures on the same high-level event
- Easily measure timing relationships between protocol and electrical domains
- Faster root-cause analysis means fewer costly finger-pointing exercises

## Analyze link training with integrated physical and protocol views

- Observe electrical-level results of protocol-level commands
- Combined navigation means always knowing which protocol and electrical behaviors happen at the same time
- No single instrument can deliver this level of cross-layer insight into link training behavior

The CrossSync PHY software option for your Teledyne LeCroy oscilloscope enables precise, intuitive navigation between time-correlated protocol analyzer and oscilloscope traces.

Oscilloscope timebase and protocol analyzer acquisition window remain synchronized while navigating through the combined acquisition, for total confidence in timing behavior.



CrossSync PHY capability enhances Teledyne LeCroy's industry-leading set of PCI Express protocol analysis interposers by adding high-fidelity oscilloscope probing points with simple and convenient signal access.

Easily probe and observe:

- High-speed data signals
- Power rail voltage and current
- Reference clock behavior
- Sideband signals

## CrossSync PHY interposers for popular PCI Express form factors

### CEM form factor



**PE230UIA-X** PCIe 5.0 CEM x16 interposer

### M.2 form factor



**PE222UIA** PCIe 5.0 M.2 M-Key Interposer

### EDSFF form factor



**PE243UIA-X** G5x4 EDSFF E1.S Interposer  
**PE241UIA-X** G5x8 EDSFF E1.L Interposer  
**PE240UIA-X** G5x16 EDSFF E3.x Interposer

### U.2/U.3 form factor



**PE221UIA-X** PCI Express 5.0 U.2/U.3 12 inch Interposer

# USB AND USB TYPE-C® ELECTRICAL TEST SOLUTIONS

In 2011, Teledyne LeCroy became the first USB-IF approved “Gold Suite” for USB 3.0 at 5 Gb/s. Today, the USB Type-C connector carries multiple lanes each up to 40 Gb/s data supporting USB4® Version 2.0, USB4, USB 3.2, Thunderbolt™ 3/4 and DisplayPort™ 2 standards. Teledyne LeCroy continues to be the trusted leader with:

- USB-IF approved “Gold Suite” PHY Tx/Rx compliance testing
- VESA approved DisplayPort over USB Type-C compliance testing
- Up to 4 lanes (8 channels) of simultaneous acquisition
- The deepest signal integrity toolbox
- Unmatched PHY-logic and USB Type-C sideband debug

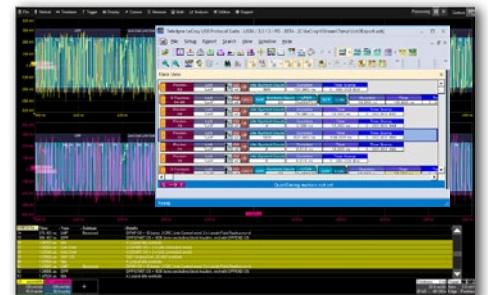
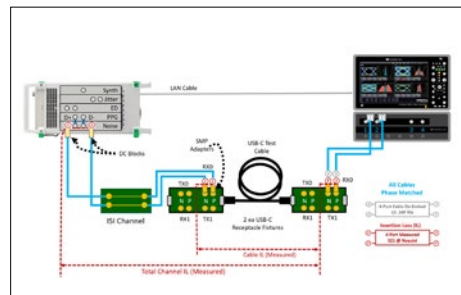
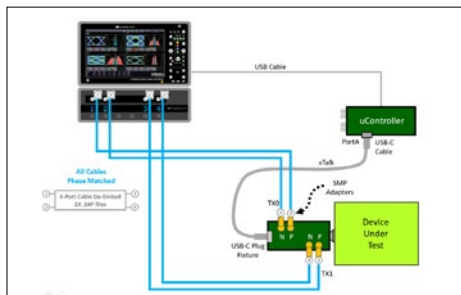

## Fastest PHY Compliance

- QualiPHY software automates all USB-C standard Transmitter (Tx) and Receiver (Rx) compliance tests using a single, friendly user interface
- Accurate, repeatable Rx testing with Anritsu MP1900A BERT
- Support for both USB-IF and 3rd party fixtures and software tools
- Single QualiPHY user interface for Tx and Rx testing

## Deepest SI Toolbox

- Choose either USB-IF SigTest or Teledyne LeCroy SDAIII analysis methodology
- Debug electrical compliance issues faster with SDAIII-CompleteLinQ eye diagrams, jitter and noise analysis software
- Characterize USB4 Version 2.0 PAM3 eye diagrams and Tx Equalization with SDAIII-PAMx software
- WavePulser 40iX simplifies and speeds up receiver channel characterization and calibration

## PHY-logic & Sideband Debug

- See the whole link with CrossSync PHY for USB4 and Thunderbolt
- USB4 and USB 3.2/2.0 serial decode options provide decode of USB packets with graphical, intuitive, color-coded decode overlays
- ProtoSync integrates industry-standard protocol display
- USB-PD (Power Delivery) TDMP and DisplayPort-AUX DMP provide unmatched visibility of USB Type-C sideband signals for system debug



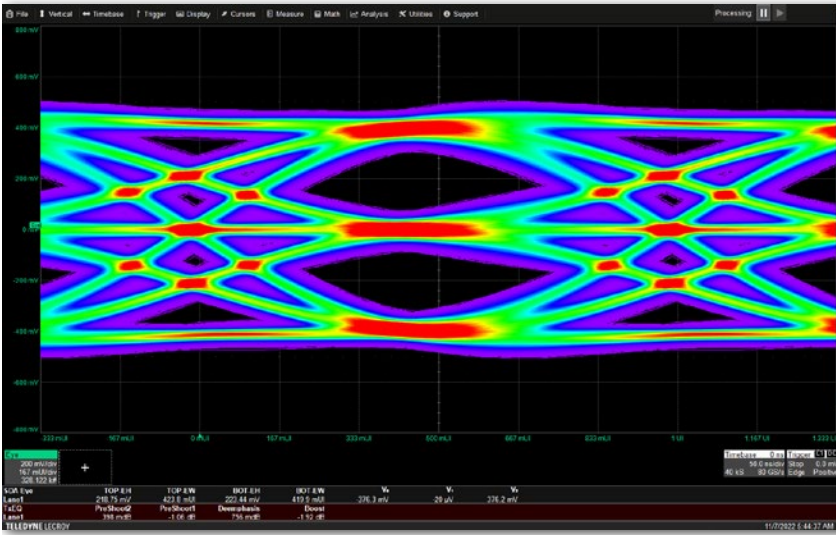

### USB4 and Thunderbolt 3/4

- QPHY-USB4-TX-RX provides automated transmitter compliance test automation per the USB4 Gen2 (10 Gb/s NRZ), Gen3 (20 Gb/s NRZ), and Version 2.0 (40 Gb/s PAM3); and Thunderbolt Gen2 (10.3125 Gb/s NRZ) and Gen3 (20.625 Gb/s NRZ) electrical Compliance Test Specifications (CTS)
- Integrates USB4 ETT for DUT control with the Wilder-Tech USB4 test controller, and Thunderbolt electrical scripts with Thunderbolt 3 controllers
- Fully automates receiver calibration and test with the Anritsu MP1900A high-speed BERT

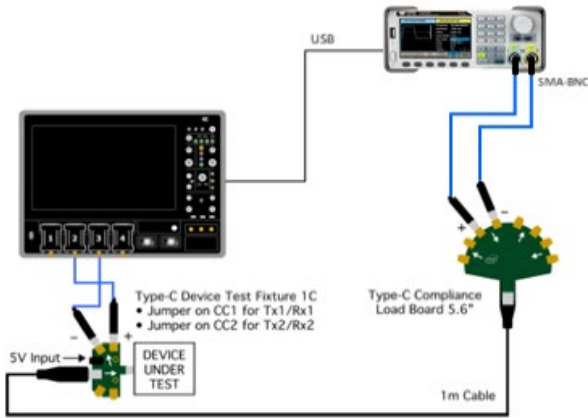

### USB 3.2

- QPHY-USB3.2-TX-RX fully automates the USB 3.2 Tx and Rx CTS for Gen1 (5 Gb/s) and Gen2 (10 Gb/s), LFPS Tx/Rx and SCD/LBPM tests
- Supports a variety of generators for Tx compliance pattern control including Teledyne Test Tools AFG, Wilder-Tech USB Type-C controllers and Anritsu MP1900A BERT
- Fully automates Rx calibration and test with the Anritsu MP1900A high-speed BERT solution

### DisplayPort over USB Type-C

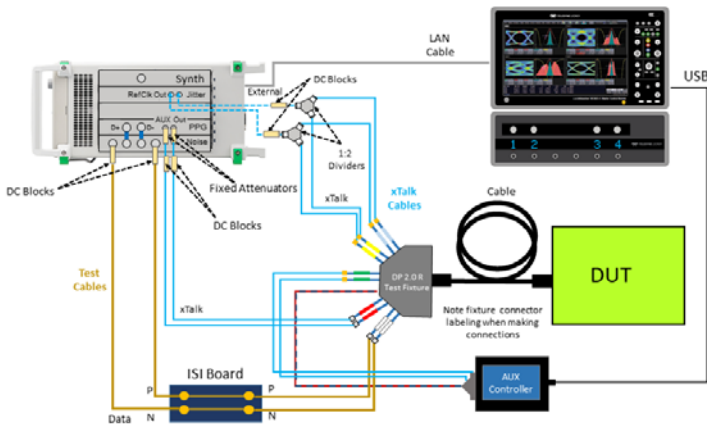

- QPHY-DP2-SOURCE software automates source (Tx) testing for all DisplayPort 2 (UHBR20, UHBR13, UHBR10 ) and 1.4a (HBR3, HBR2, HBR, RBR) data rates up to four lanes
- QPHY-DP2-SINK software automates DisplayPort 2 and 1.4a sink (Rx) calibration and testing with the Anritsu MP1900A high-speed BERT solution
- DPAUX DMP provides AUX channel decode, serial data measurements and physical layer measurements
- Supports all VESA approved test fixtures including Standard/Enhanced DP, mDP and USB Type-C

# CrossSync™ PHY FOR USB4® AND THUNDERBOLT™

Interoperability issues can lead to finger-pointing exercises that cost money and time-to-market. Teledyne LeCroy CrossSync PHY software merges the functions of your Teledyne LeCroy protocol analyzer and oscilloscope - giving insight into link behavior that no other instrument can provide.

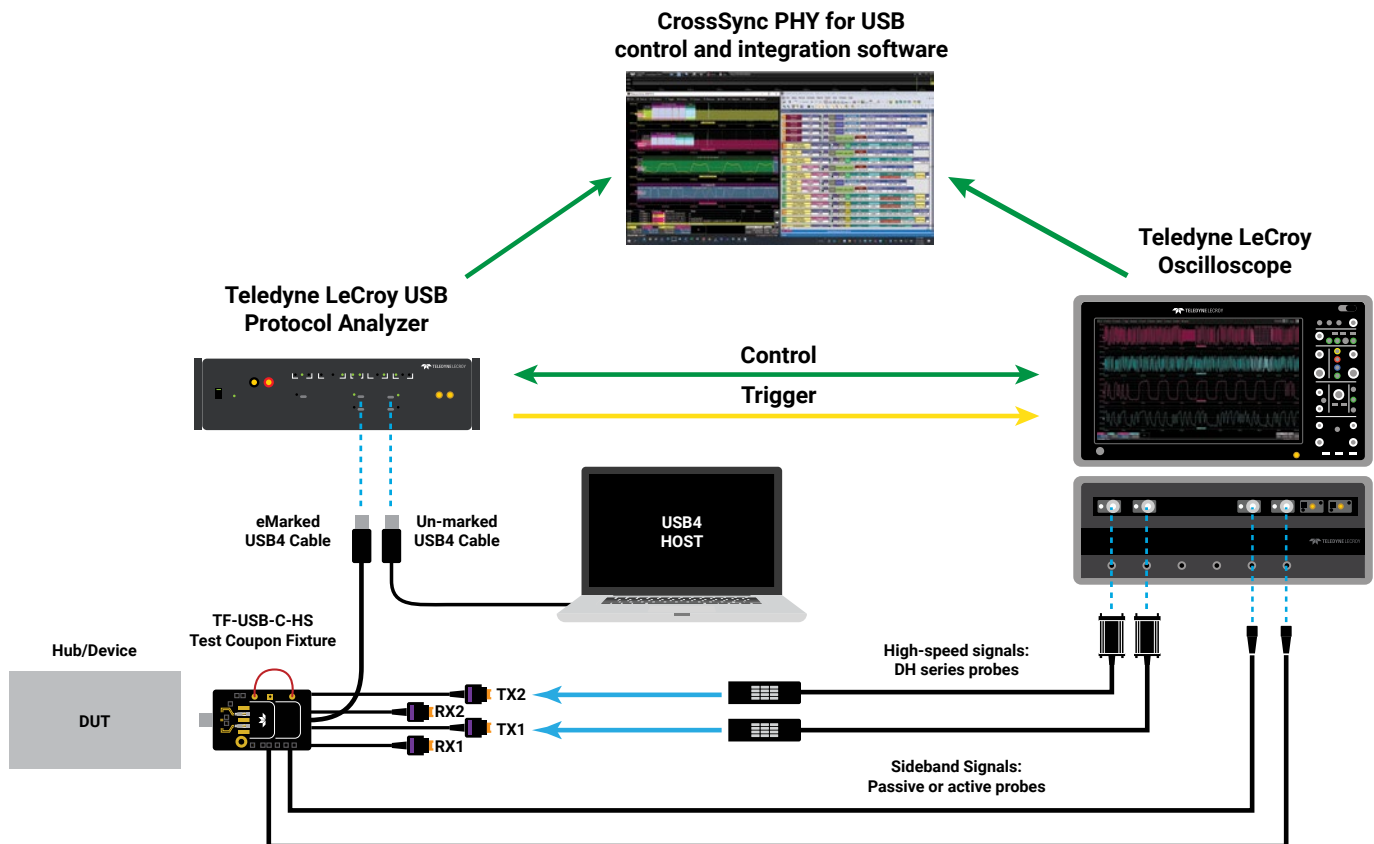

## Validate and debug active link operation

- TF-USB-C-HS Test Coupon Fixtures enable observation of both electrical and protocol behavior without disturbing the link
- USB Type-C Sideband signals are all accessible using passive or active probes
- High-bandwidth oscilloscope probing points for USB data lanes

## Quickly resolve interoperability issues by capturing the entire protocol stack

- Trigger protocol analyzer and oscilloscope captures on the same high-level event
- Easily measure timing relationships between protocol and electrical domains
- Faster root-cause analysis means fewer costly finger-pointing exercises

## Analyze link training with integrated physical and protocol views

- Observe electrical-level results of protocol-level commands
- Combined navigation means always knowing which protocol and electrical behaviors happen at the same time
- No other solution can deliver this level of cross-layer insight into link training

The CrossSync PHY software option for your Teledyne LeCroy oscilloscope enables precise, intuitive navigation between time-correlated protocol analyzer and oscilloscope traces.

Oscilloscope timebase and protocol analyzer acquisition window remain synchronized while navigating through the combined acquisition, for total confidence in timing behavior.



**CrossSync PHY capability enhances Teledyne LeCroy’s industry-leading Protocol Analyzer/Exercisers by adding high-fidelity oscilloscope probing points with simple and convenient signal access using USB Type-C Test Coupon Fixtures.**

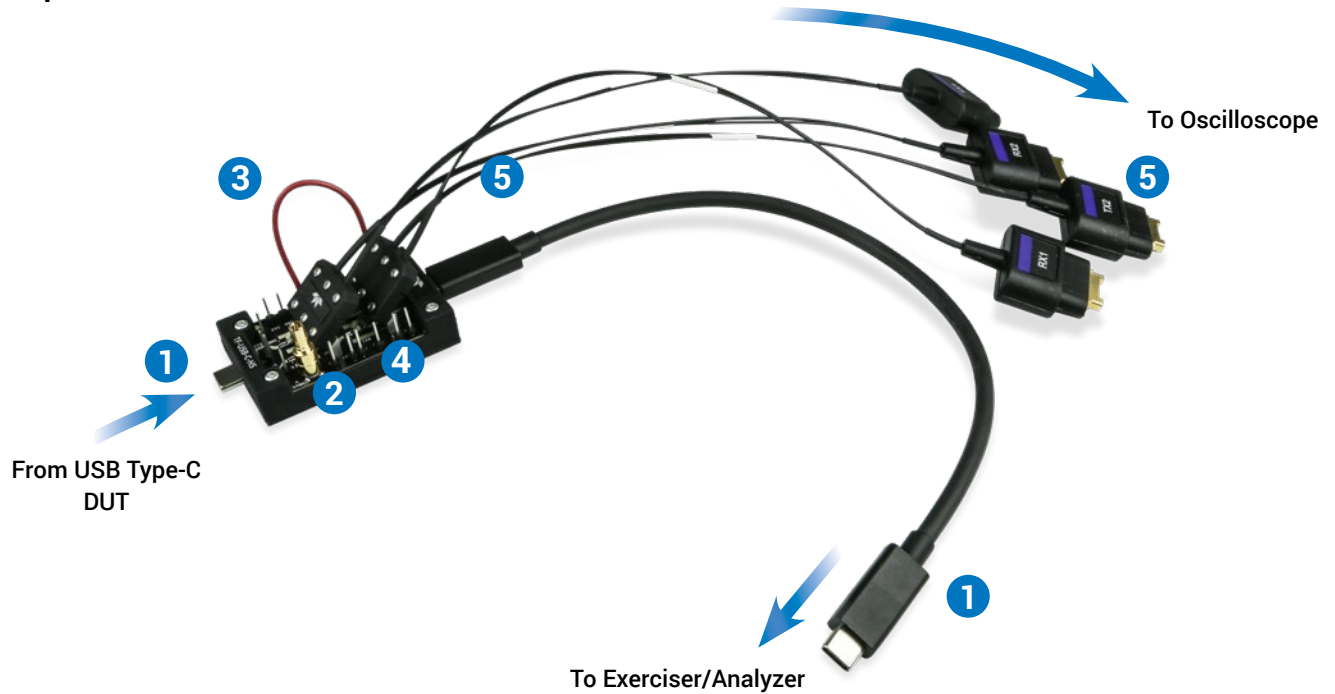

- 1. Transparent signal path through the test coupon fixture’s USB-C Plug, Receptacle, and included 0.3 meter USB Type-C cable
- 2. Vbus access using Active Single Ended or Voltage Rail Probe
- 3. Current loop for measuring Vbus current through the test coupon fixture
- 4. Access SBU1/SBU2 (USB4 Sidebands and DP-AUX), CC1/CC2 (Power Delivery), and D+/D- (USB1.1/2.0) signals using square pins
- 5. High-speed TX1/TX2 and RX1/RX2 signals captured using a permanently attached DH-SI Series probe tips

# QUALIPHY AUTOMATED SOFTWARE TEST FRAMEWORK

QualiPHY is Teledyne LeCroy's automated software test framework for performing standardized tests on high-speed serial interfaces. QualiPHY automation software is available for PCI Express, USB, DDR, DisplayPort, HDMI and other technologies - for a full list, see our **Oscilloscope Features, Options, and Accessories catalog**.

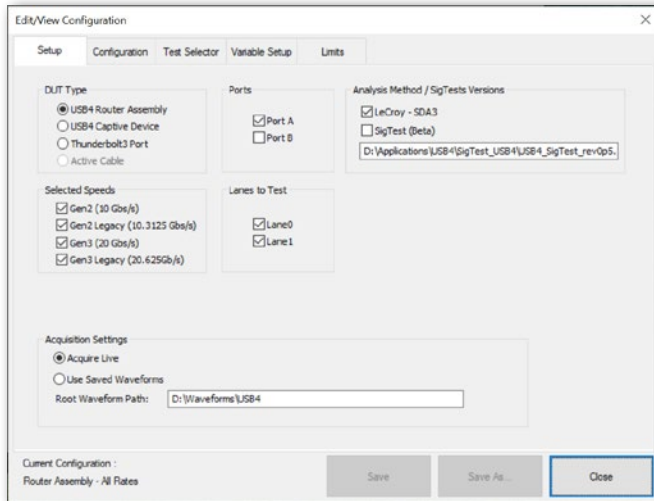

## Simplified Setup

QualiPHY dialogs help the user configure all aspects of test execution, including:

- Selecting the set of tests to run
- Configuring test parameters
- Customizing limits
- Options to stop after each test or execute sequentially

## Streamlined Test Execution

QualiPHY guides the user through connection and execution of each test, resulting in increased repeatability.

- Clear, informative connection diagrams help simplify complex test setups and reduce mistakes
- Dialogs explain test execution and required Device Under Test (DUT) settings
- Simple, powerful Host Program Control interface enables complete automation of QualiPHY with external scripting environments (for selected QualiPHY products)

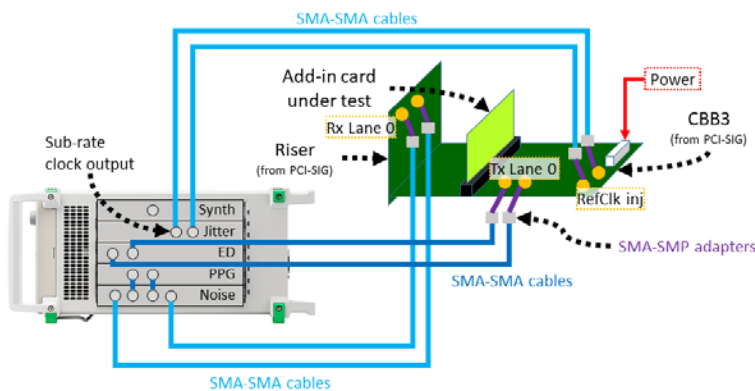

## Informative Reporting

QualiPHY produces comprehensive reports documenting test results.

- Save reports in PDF or HTML format
- Screenshots and tabular results included
- Summary table at the start of the report makes it easy to tell pass/fail results at a glance

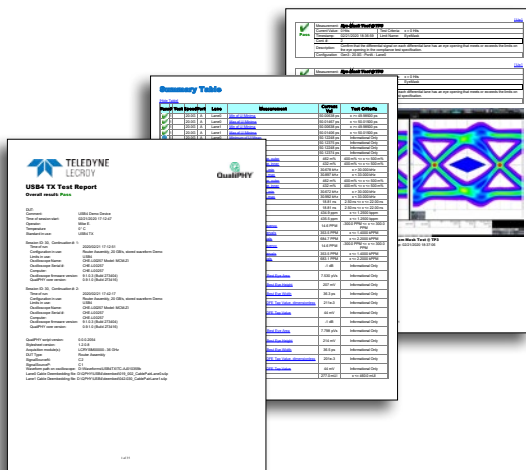



# HIGH BANDWIDTH DIFFERENTIAL PROBES

The DH series of 8 to 30 GHz active differential probes provides high input dynamic range, large offset capability, low loading and excellent signal fidelity with a range of connection options.

## General Purpose Probing up to 30 GHz

Teledyne LeCroy's DH series of 8 GHz to 30 GHz differential probes offer the combination of bandwidth, input range and offset capability to address any high-speed probing requirement - from debugging serial data interfaces to validating DDR memory systems.

## Exceptional Signal Fidelity

DH series probes provide superior loading characteristics and are calibrated with a custom "fine-tuned" frequency response. The ultra-low loading and flat frequency response ensure accurate measurements.

## Wide Variety of Tips

Two 30 GHz solder-in leads let you choose between a 3.5 Vpp input range for general-purpose applications, or high sensitivity with exceptionally low noise. Also available are a 1-meter long 16 GHz high-temperature tip, a 16 GHz handheld browser tip and an 8 GHz QuickLink adapter for connecting mixed-signal probe tips.



## Tip Identification

Each DH series tip has its own data onboard - the oscilloscope software automatically selects the correct tip type and precisely corrects for its effects. The result is superior signal fidelity and superior ease-of-use.

## Digital Logic Probing Options

### HDA125 High-speed Digital Analyzer

The HDA125 turns your Teledyne LeCroy oscilloscope into the highest-performance, most flexible mixed-signal solution with 12.5 GS/s digital sampling rate (3 GHz digital clock rate) on 18 input channels and the QuickLink probing solution. Ideal for validation of DDR interfaces.



# POWERFUL, DEEP TOOLBOX

Capture		View			Measure		Math		Analyze										Document
Triggering	Acquire	Display Grids	Display Views	Zooming	Parameters	Parameter Analysis	Functions	Advanced Functions	Pass/Fail	Anomaly Detection	Serial Decode	Serial Message Analysis	Clock & Timing Jitter	Serial Data Jitter	Serial Data Analysis	Application Packages	Document		
1 Exclusion	2 Measurement	3 5 MS/s Roll	4	5	6	7	8	9	10	11 Multistage	12 Sequence Mode	13 Protocol Table	14 Jitter Overlay	15 TJ, RJ, DJ	16 PAM-4 Analysis	17-22 Motor + Power	23 Compliance		
24 Analog-Digital	25 80ch 4 to 80 Channels	26 Multi-Grid	27 Segment	28 Multi-Zoom	29 All Instance	30 Statistics	31 Full Memory FFT	32 Digital Filters	33 Mask Test	34 TriggerScan	35 Symbol	36 Search & Zoom	37 Jitter Track	38 Bathtub Curve	39 Rj + Blj Views	40-45 DDR Analysis	46 WaveStudio		
47 Serial Data	48 HD 4096 High Definition Technology	49 Drag and Drop	50 Waveform Histogram	51 Vertical Zoom	52 Parameter Math	53 Parameter Acceptance	54 Tracks / Trends	55 Processing Web	56 Actions	57 WaveScan	58 Protocol Layer	59 Bus Parameters	60 Jitter Histogram	61 IsoBER	62 DJ Views	63-67	68 LSB		
69	70 100 GHz / DBI	71 Q-Scope	72 3D Persistence	73 Auto-Scroll	74 Custom Measure	75 Histogram/Histogram	76 Demodulation	77 Custom Math	78 Boolean Compare	79 History Mode	80 Application Layer	81 Timing Parameters	82 Jitter Spectrum	83 Jitter Simulation	84 Noise + Crosstalk	85-89	90 LabNotebook		
91	92	93	94	95	96	97	98	99	100	101	102 ProtoSync	103 Serial DAC Waveform	104 JitKit Views	105 EyeDr / VP	106 VectorLinQ VSA	107-114	115 Automation		
117	118 Mod	119 Control Loop	120 Harmonics	121 3-Phase	122 Static+Dynamic	123 Zoom+Gate	124	125	126	127	128	129	130	131 Ethernet	132 DDR	133 Video	134 mipi		
140	141 R/W Separation	142 Multi-Eye View	143 DDR TJ, RJ, DJ	144 Debug Toolkit	145 Virtual Probe	146	147	148	149	150	151 Automotive	152 PCI EXPRESS	153 USB	154 Storage					

**Element Key:**

- ▲ Invented by LeCroy
- ★ Unique to LeCroy

## Our heritage

Teledyne LeCroy's 50+ year heritage is in processing long records to extract meaningful insight. We invented the digital oscilloscope and many of the additional waveshape analysis tools.

## Our obsession

Our tools and operating philosophy are standardized across much of our product line. This deep toolbox inspires insight; and your moment of insight is our reward.

## Our invitation

Our Periodic Table of Oscilloscope Tools explains the toolsets that Teledyne LeCroy has deployed in our oscilloscopes. Visit our interactive website to learn more about them.

[teledynelecroy.com/tools](http://teledynelecroy.com/tools)

# MAUI STUDIO - WORKS WHERE YOU ARE

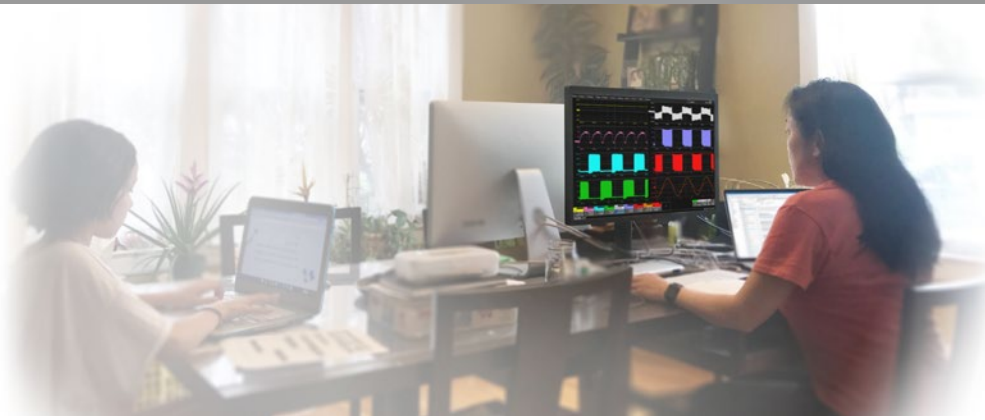

**Unleash the power of a Teledyne LeCroy oscilloscope anywhere, using a PC with MAUI Studio Pro. Work remotely from your oscilloscope and collaborate with ease.**

## Flexibility to Work Anywhere

MAUI Studio provides the flexibility to remotely work anywhere, and allows anyone anywhere to execute real-time analysis by connecting to an oscilloscope through an Ethernet connection or by analyzing a saved LabNotebook.

## Collaborate with Ease

Using MAUI Studio, you can share a LabNotebook file saved from an oscilloscope with all of your colleagues, and everyone will have access to the same software options that are found on your oscilloscope.

## The Power of MAUI Studio

Get all the unbelievable analytical capabilities of your oscilloscope on your PC. MAUI Studio has all the analysis tools needed to analyze complex waveform data, enabling your lab's oscilloscopes to be freed up for other activities.

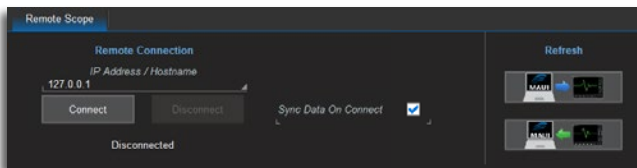

## Remote Connection

- Connect to an oscilloscope through an Ethernet connection
- Transfer waveforms and setups from an oscilloscope to MAUI Studio Pro
- Transfer setups from MAUI Studio Pro to an oscilloscope
- Import software options by establishing a remote connection to an oscilloscope

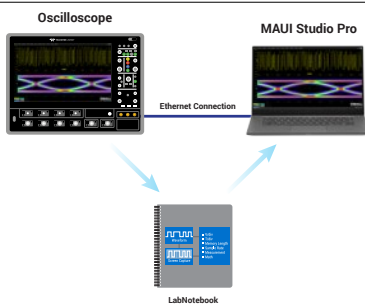

## Offline Analysis

- Recall a LabNotebook file to analyze saved waveforms, measurements and setups
- Import software options by recalling a LabNotebook file
- Have access to the same software found on your oscilloscope

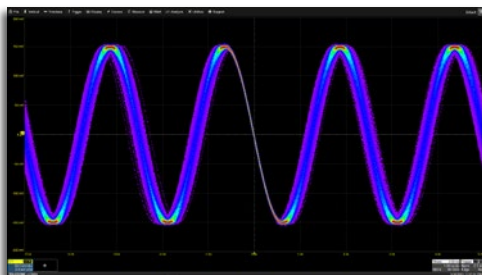

## Arbitrary Function Generator

- Generate advance waveforms using the AFG
- Easily generate a PAM4 signal
- Add jitter to a clock signal to simulate real-world signal integrity impairments

Try the free MAUI Studio Pro 30 day trial. Download and register at [teledynelecroy.com/mauistudio](https://teledynelecroy.com/mauistudio).

# SPECIFICATIONS

**LabMaster  
10-20Zi-A**

**LabMaster  
10-25Zi-A**

**LabMaster  
10-30Zi-A**

**LabMaster  
10-36Zi-A**

## Vertical System

Analog Bandwidth @ 50 Ω (-3 dB) (2.4/2.92mm Inputs)	20 GHz (≥5 mV/div)	25 GHz (≥5 mV/div)	30 GHz (≥5 mV/div)	36 GHz (≥5 mV/div)
Rise Time (10–90%, 50 Ω - test limit)	19.3 ps (test limit, flatness mode)	15.4 ps (test limit, flatness mode)	12.8 ps (test limit, flatness mode)	10.7 ps (test limit, flatness mode)
Rise Time (20–80%, 50 Ω - typical)	14.5 ps (flatness mode)	11.6 ps (flatness mode)	9.6 ps (flatness mode)	8.0 ps (flatness mode)
Input Channels	Up to 80, depending on configuration selected. (Any combination of up to 80 2.92mm input channels)			
Vertical Resolution	8 bits; up to 11 bits with enhanced resolution (ERES)			
Effective Number of Bits (ENOB)*	5.32	5.16	5.03	4.90
Vertical Noise Floor (rms, typical, 50 Ω)				
5 mV/div	0.38 mV	0.44 mV	0.49 mV	0.56 mV
10 mV/div	0.38 mV	0.44 mV	0.49 mV	0.56 mV
20 mV/div	0.64 mV	0.74 mV	0.81 mV	0.92 mV
50 mV/div	1.40 mV	1.60 mV	1.70 mV	1.88 mV
100 mV/div	3.38 mV	3.88 mV	4.28 mV	4.83 mV
200 mV/div	6.10 mV	6.98 mV	7.53 mV	8.30 mV
500 mV/div	14.00 mV	16.00 mV	17.00 mV	18.25 mV

\* Average value across bandwidth, input signal 87.5% of full scale

Sensitivity **50 Ω (2.92mm):** 5 mV–500mV/div, fully variable (5-9.9 mV/div via zoom)

DC Vertical Gain Accuracy  
(Gain Component of DC Accuracy) ±1% F.S. (typical), offset at 0V; ±1.5% F.S. (test limit), offset at 0V

Channel-Channel  
Isolation **DC to 36 GHz:** 60 dB (>1000:1)  
(For any two 2.92mm input channels, same or different v/div settings, typical)

Offset Range **50 Ω:**  
±500 mV @ 5-75 mV/div  
±4 V @ 76 mV/div -500mV/div

DC Vertical Offset Accuracy ±(1.5% of offset setting + 1.5% F.S. + 1 mV) (test limit)

## Vertical System

Maximum Input Voltage **2.92 mm Inputs:** ±2 V<sub>max</sub>@<76mV/div, 5.5V<sub>rms</sub>@≥76mV/div

Input Coupling **2.92 mm Inputs:** 50 Ω: DC, GND

Input Impedance **2.92mm Inputs:** 50 Ω+/-2%

Bandwidth Limiters Fully variable from 1 GHz to instrument bandwidth in increments of 100 MHz

Rescaling **Length:** meters, inches, feet, yards, miles; **Mass:** grams, slugs; **Temperature:** celsius, fahrenheit, kelvin; **Angle:** radian, arcdeg, arcmin, arcsec, cycles, revolutions, turns; **Velocity:** m/s, in/s, ft/s, yd/s, miles/s; **Acceleration:** m/s<sup>2</sup>, in/s<sup>2</sup>, ft/s<sup>2</sup>, g0; **Volume:** liters, cubic meters, cubic inches, cubic feet, cubic yards; **Force (Weight):** newton, grain, ounce, pound; **Pressure:** pascal, bar, atmosphere (technical), atmosphere (standard), torr, psi; **Electrical:** volts, amps, watts, volt-amperes, volt-amperes reactive, farad, coulomb, ohm, siemen, volt/meter, coulomb/m<sup>2</sup>, farad/meter, siemen/meter, power factor; **Magnetic:** weber, tesla, henry, amp/meter, henry/meter; **Energy:** joule, Btu, calorie; **Rotating Machine:** radian/second, frequency, revolution/second, revolution/minute, N-m, lb-ft, lb-in, oz-in, watt, horsepower; **Other:** %.

## Horizontal - Analog Channels

Timebases Internal timebase with 10 GHz clock frequency common to all input channels. Single, distributed 10 GHz clock for all channels ensures precise synchronization with timing accuracy between all channels identical to that provided within a single, conventional oscilloscope package.

Time/Division Range 10 ps/div–256 s/div (maximum capture time is based on minimum sample rate of 200kS/s and installed memory).

Clock Accuracy < 0.1 ppm + (aging of 0.05ppm/yr from last calibration)



# SPECIFICATIONS

	LabMaster 10-50Zi-A	LabMaster 10-59Zi-A	LabMaster 10-65Zi-A
<b>Vertical System</b>			
Analog Bandwidth @ 50 Ω (-3 dB) (1.85mm Inputs)	50 GHz (≥10 mV/div)	59 GHz (≥10 mV/div)	65 GHz (≥10 mV/div)
Analog Bandwidth @ 50 Ω (-3 dB) (2.4/2.92mm Inputs)	36 GHz (≥5 mV/div)	36 GHz (≥5 mV/div)	36 GHz (≥5 mV/div)
Rise Time (10–90%, 50 Ω - test limit)	8 ps (test limit, flatness mode)	6.9 ps (test limit, flatness mode)	6.5 ps (test limit, flatness mode)
Rise Time (20–80%, 50 Ω - typical)	6 ps (flatness mode)	5.2 ps (flatness mode)	4.9 ps (flatness mode)
Input Channels	Up to 40, depending on configuration selected. Up to 80 @ 36 GHz		
Vertical Resolution	8 bits; up to 11 bits with enhanced resolution (ERES)		
Effective Number of Bits (ENOB)*	4.79	4.67	4.60
Vertical Noise Floor (rms, 50 Ω)			
10 mV/div	0.89 mV	0.95 mV	0.97 mV
20 mV/div	1.48 mV	1.58 mV	1.61 mV
50 mV/div	3.20 mV	3.45 mV	3.55 mV
80 mV/div	5.05 mV	5.6 mV	5.75 mV

\* Average value across bandwidth, input signal 87.5% of full scale

Sensitivity	<b>50 Ω (2.92mm):</b> 5 mV–500mV/div, fully variable (5-9.9 mV/div via zoom) <b>50 Ω (1.85mm):</b> 10 mV–80mV/div, fully variable. Higher gain settings possible through use of external attenuators.
DC Vertical Gain Accuracy (Gain Component of DC Accuracy)	±1% F.S. (typical), offset at 0 V; ±1.5% F.S. (test limit), offset at 0 V
Channel-Channel Isolation	<b>DC to 36 GHz:</b> 60 dB (>1000:1) (For any two 2.92mm input channels, same or different v/div settings, typical) <b>36 to 65 GHz:</b> 40 dB (>100:1) (For any two 1.85mm input channels, same or different v/div settings, typical)
Offset Range	<b>50 Ω (1.85 mm):</b> ±500 mV @ 10–80 mV/div <b>50 Ω (2.92mm):</b> ±500 mV @ 5-75 mV/div ±4 V @ 76 mV/div -500mV/div
DC Vertical Offset Accuracy	±(1.5% of offset setting + 1.5% F.S. + 1 mV) (test limit)

## Vertical System

Maximum Input Voltage	<b>2.92 mm Inputs:</b> ±2 V <sub>max</sub> @<76mV/div, 5.5V <sub>rms</sub> @≥76mV/div <b>1.85 mm Inputs:</b> ±2 V <sub>max</sub> @≤80mV/div
Input Coupling	<b>2.92 mm Inputs:</b> 50 Ω: DC, GND <b>1.85 mm Inputs:</b> 50 Ω: DC
Input Impedance	<b>2.92mm Inputs:</b> 50 Ω+/-2% <b>1.85mm Inputs:</b> 50 Ω+/-2%
Bandwidth Limiters	Fully variable from 1 GHz to instrument bandwidth in increments of 100 MHz
Rescaling	<b>Length:</b> meters, inches, feet, yards, miles; <b>Mass:</b> grams, slugs; <b>Temperature:</b> celsius, fahrenheit, kelvin; <b>Angle:</b> radian, arcdegr, arcmin, arcsec, cycles, revolutions, turns; <b>Velocity:</b> m/s, in/s, ft/s, yd/s, miles/s; <b>Acceleration:</b> m/s <sup>2</sup> , in/s <sup>2</sup> , ft/s <sup>2</sup> , g0; <b>Volume:</b> liters, cubic meters, cubic inches, cubic feet, cubic yards; <b>Force (Weight):</b> newton, grain, ounce, pound; <b>Pressure:</b> pascal, bar, atmosphere (technical), atmosphere (standard), torr, psi; <b>Electrical:</b> volts, amps, watts, volt-amperes, volt-amperes reactive, farad, coulomb, ohm, siemen, volt/meter, coulomb/m <sup>2</sup> , farad/meter, siemen/meter, power factor; <b>Magnetic:</b> weber, tesla, henry, amp/meter, henry/meter; <b>Energy:</b> joule, Btu, calorie; <b>Rotating Machine:</b> radian/second, frequency, revolution/second, revolution/minute, N·m, lb-ft, lb-in, oz-in, watt, horsepower; <b>Other:</b> %.

## Horizontal - Analog Channels

Timebases	Internal timebase with 10 GHz clock frequency common to all input channels. Single, distributed 10 GHz clock for all channels ensures precise synchronization with timing accuracy between all channels identical to that provided within a single, conventional oscilloscope package.
Time/Division Range	<b>For &gt;36 GHz Mode:</b> 10 ps/div - 320 μs/div (maximum capture time is based on 160 GS/s and installed memory). <b>For ≤36 GHz Mode:</b> 10 ps/div–256 s/div (maximum capture time is based on minimum sample rate of 200ks/s and installed memory).
Clock Accuracy	< 0.1 ppm + (aging of 0.05 ppm/yr from last calibration)

# SPECIFICATIONS

**LabMaster  
10-20Zi-A**

**LabMaster  
10-25Zi-A**

**LabMaster  
10-30Zi-A**

**LabMaster  
10-36Zi-A**

## Horizontal - Analog Channels (cont'd)

Sample Clock Jitter	<p><b>Up to 3.2ms Acquired Time Range:</b> 50fsrms (Internal Timebase Reference) 50fsrms (External Timebase Reference)</p> <p><b>Up to 6.4ms Acquired Time Range:</b> 130fsrms (Internal Timebase Reference) 130fsrms (External Timebase Reference)</p>
Delta Time Measurement Accuracy	$\sqrt{2} * \sqrt{\left(\frac{Noise}{SlewRate}\right)^2} + (Sample\ Clock\ Jitter)^2 (RMS) + (clock\ accuracy * reading) (seconds)$
Jitter Measurement Floor	$\sqrt{\left(\frac{Noise}{SlewRate}\right)^2} + (Sample\ Clock\ Jitter)^2 (RMS, seconds, TIE)$
Jitter Between Channels	<250fsrms (TIE, typical, measured at maximum bandwidth)
Channel-Channel Deskew Range	±9 x time/div. setting, or 25 ns max., each channel
External Timebase Reference (Input)	10 MHz or 100MHz; 50 Ω impedance, applied at the rear input of MCM-Zi-A Master Control Module
External Timebase Reference (Output)	10 MHz or 100 MHz ; 50 Ω impedance, output at the rear of MCM-Zi-A Master Control Module

## Acquisition - Analog Channels

Sample Rate (Single-Shot)	80 GS/s on each channel.		
Standard Memory	32 Mpts, 1,000 segments		
Memory Options	<b>Option</b>	<b>Mem/Ch</b>	<b>Max Segments</b>
	S-32	32 Mpts	7,500
	M-64	64 Mpts	15,000
	L-128	128 Mpts	15,000
	VL-256	256 Mpts	15,000
	XL-512	512 Mpts	15,000
Intersegment time	1 μs		
Averaging	Summed averaging to 1 million sweeps; continuous averaging to 1 million sweeps		
Enhanced Resolution (ERES)	From 8.5 to 11 bits vertical resolution		
Envelope (Extrema)	Envelope, floor, or roof for up to 1 million sweeps		
Interpolation	Linear or Sin x/x		

## Vertical, Horizontal, Acquisition - Digital Channels with HDA125-18-SYNC

Maximum Input Frequency	3 GHz
Minimum Detectable Pulse Width	167ps
Input Dynamic Range	±10V on any single ended input ±7.5V max differential
Input Impedance (Flying Leads)	QL-SI tips: 110 kΩ, 0.12pF differential
Input Channels	18 Digital Channels
Maximum Input Voltage	±15V on any single ended input ±15V max differential
Minimum Input Voltage Swing	150 mV p-p
Threshold Selections	User defined
Threshold Accuracy	±(25mV + 3% of threshold setting)
User Defined Threshold Range	±5V, settable per channel in 5 mV steps
User Defined Hysteresis Range	50mV - 600mV settable per channel
Sample Rate	12.5 GS/s
Channel-to-Channel Skew	±160ps
Deskew Range	±1.6ns in 80ps steps

# SPECIFICATIONS

**LabMaster  
10-50Zi-A**

**LabMaster  
10-59Zi-A**

**LabMaster  
10-65Zi-A**

## Horizontal - Analog Channels (cont'd)

Sample Clock Jitter	<b>Up to 3.2ms Acquired Time Range:</b> 50fsrms (Internal Timebase Reference) 50fsrms (External Timebase Reference) <b>Up to 6.4ms Acquired Time Range:</b> 130fsrms (Internal Timebase Reference) 130fsrms (External Timebase Reference)		
Delta Time Measurement Accuracy	$\sqrt{2} * \sqrt{\left(\frac{Noise}{SlewRate}\right)^2 + (Sample\ Clock\ Jitter)^2 (RMS) + (clock\ accuracy * reading) (seconds)}$		
Jitter Measurement Floor	$\sqrt{\left(\frac{Noise}{SlewRate}\right)^2 + (Sample\ Clock\ Jitter)^2 (RMS, seconds, TIE)}$		
Jitter Between Channels	<190fsrms (TIE, typical, measured at maximum bandwidth)	<150fsrms (TIE, typical, measured at maximum bandwidth)	<130fsrms (TIE, typical, measured at maximum bandwidth)
Channel-Channel Deskew Range	±9 x time/div. setting, or 25 ns max., each channel		
External Timebase Reference (Input)	10 MHz or 100MHz; 50 Ω impedance, applied at the rear input of MCM-Zi-A Master Control Module		
External Timebase Reference (Output)	10 MHz or 100 MHz ; 50 Ω impedance, output at the rear of MCM-Zi-A Master Control Module		

## Acquisition - Analog Channels

Sample Rate (Single-Shot)	160 GS/s on each channel in >36 GHz Mode. 80 GS/s on each channel in ≤36 GHz Mode.		
Standard Memory	64 Mpts, 1,000 segments		
Memory Options	<b>Option</b>	<b>Mem/Ch</b>	<b>Max Segments</b>
	S-32	64 Mpts	3,500
	M-64	128 Mpts	7,500
	L-128	256 Mpts	15,000
	VL-256	512 Mpts	15,000
	XL-512	1024 Mpts	15,000
	(In ≤36 GHz Modes, reference memory specification for LabMaster 10 Zi-A 36 GHz Systems)		
Intersegment time	1 μs		
Averaging	Summed averaging to 1 million sweeps; continuous averaging to 1 million sweeps		
Enhanced Resolution (ERES)	From 8.5 to 11 bits vertical resolution		
Envelope (Extrema)	Envelope, floor, or roof for up to 1 million sweeps		
Interpolation	Linear or Sin x/x		

## Vertical, Horizontal, Acquisition - Digital Channels with HDA125-18-SYNC

Maximum Input Frequency	3 GHz
Minimum Detectable Pulse Width	167ps
Input Dynamic Range	±10V on any single ended input ±7.5V max differential
Input Impedance (Flying Leads)	QL-SI tips: 110 kΩ, 0.12pF differential
Input Channels	18 Digital Channels
Maximum Input Voltage	±15V on any single ended input ±15V max differential
Minimum Input Voltage Swing	150 mV p-p
Threshold Selections	User defined
Threshold Accuracy	±(25mV + 3% of threshold setting)
User Defined Threshold Range	±5V, settable per channel in 5 mV steps
User Defined Hysteresis Range	50mV - 600mV settable per channel
Sample Rate	12.5 GS/s
Channel-to-Channel Skew	±160ps
Deskew Range	±1.6ns in 80ps steps

# SPECIFICATIONS

	LabMaster 10-20Zi-A	LabMaster 10-25Zi-A	LabMaster 10-30Zi-A	LabMaster 10-36Zi-A
<b>Triggering System</b>				
Modes	Normal, Auto, Single and Stop			
Sources	Any Ch 1-4 (Edge, Window, SMART, Cascade triggers), AUX, internal Fast Edge; or any input channel (Edge trigger only) on additional 10-xxZi-A Acquisition Modules (Channels 5 and higher). Slope and level unique to each source except line trigger.			
Coupling	DC, AC, HFRej, LFRej			
Pre-trigger Delay	0 to 100% of memory size (adjustable in 1% increments of 100 ns)			
Post-trigger Delay	0–10,000 divisions in real time mode, limited at slower time/div settings			
Hold-off	From 2 ns up to 20 s or from 1 to 99,999,999 events			
Trigger and Interpolator Jitter	<0.1 ps rms (typical, software assisted), 2 ps rms (typical, hardware)			
Internal Trigger Level Range	±4.1 div from center			
External Trigger Level Range	For any LabMaster 10xx-Zi-A Acquisition Module: Aux (±0.4 V) (Only Ch1-4 Acquisition Module has "active" AUX Input)			
Maximum Trigger Rate	1,000,000 waveforms/second (in Sequence Mode, up to 4 channels)			
Trigger Sensitivity with Edge Trigger (1.85/2.4/2.92mm Inputs)	For Ch 1-80 of a LabMaster 10 Zi-A system: 3 div @ < 12 GHz 1.5 div @ < 3 GHz 1.0 div @ < 200 MHz (for DC coupling, ≥ 10 mV/div, 50 Ω)			
Trigger Sensitivity with Edge Trigger (Aux Input)	For Ch 1-4 LabMaster 10xx-Zi-A Acquisition Module: 2 div @ < 1 GHz, 1.5 div @ < 500 MHz, 1.0 div @ < 200 MHz, (for DC coupling)			
Max. Trigger Frequency, SMART Trigger	For Ch 1-4 only of any LabMaster 10xx-Zi-A Acquisition Module: 2.0 GHz @ ≥ 10 mV/div (minimum triggerable width 200 ps)			
<b>Trigger Types</b>				
Edge	Triggers when signal meets slope (positive, negative, or either) and level condition.			
Width	Triggers on positive, negative or both (widths selectable as low as 200ps to 20 s) or on intermittent faults.			
Glitch	Triggers on positive or negative glitches (widths selectable as low as 200ps to 20 s) or on intermittent faults.			
Window	Triggers when signal exits a window defined by adjustable thresholds.			
Pattern	Logic combination (AND, NAND, OR, NOR) of 5 inputs (4 channels and external trigger input). Each source can be high, low or don't care. The high and low level can be selected independently. Triggers at start or end of the pattern.			
Runt	Trigger on positive or negative runts defined by two voltage limits and two time limits. Select between 1 ns and 20 ns.			
Slew Rate	Trigger on edge rates. Select limits for dV, dt and slope. Select edge limits between 1 ns and 20 ns.			
Interval	Triggers on intervals selectable between 1 ns and 20 s.			
Dropout	Triggers if signal drops out for longer than selected time between 1 ns and 20 s.			
Exclusion Triggering	Trigger on intermittent faults by specifying the expected behavior and triggering when that condition is not met.			
Measurement Trigger	Select from a large number of measurement parameters trigger on a measurement value with qualified limits. Can be used as only trigger or last event in a Cascade Trigger.			
Multi-stage: Qualified	Triggers on any input source only if a defined state or edge occurred on another input source. Holdoff between sources is selectable by time or events.			
Multi-stage: Qualified First	In Sequence acquisition mode, triggers repeatably on event B only if a defined pattern, state or edge (event A) is satisfied in the first segment of the acquisition. Holdoff between sources is selectable by time or events.			
Multi-Stage: Cascade (Sequence) Trigger, Capability	Arm on "A" event, then Trigger on "B" event. Or Arm on "A" event, then Qualify on "B" event, and Trigger on "C" event.			
Multi-Stage: Cascade (Sequence) Trigger, Types	Cascade A then B: Edge, Window, Pattern (Logic) Width, Glitch, Interval, Dropout, or Measurement. Measurement can be on Stage B only. Cascade A then B then C (Measurement): Edge, Window, Pattern (Logic), Width, Glitch, Interval, Dropout, or Measurement. Measurement can be on Stage C only. Cascade A then B then C: Edge, Window, Pattern (Logic)			
Multi-Stage: Cascade (Sequence) Trigger, Holdoff	Holdoff between A and B or B and C is selectable by time or number of events. Measurement trigger selection as the last stage in a Cascade precludes a holdoff setting between the prior stage and the last stage.			
<b>High-speed Serial Protocol Triggering (Optional)</b>				
Data Rates	Option LM10Zi-6GBIT-80B-SYMBOL-TD: 600 Mb/s to 6.5 Gb/s, Channel 4 input only Option LM10Zi-14GBIT-80B-SYMBOL-TD: 600 Mb/s to 14.1 Gb/s, Channel 4 input only (Note: 64b/66b triggering only available on signal rates ≥ 6.25 Gb/s)			
Pattern Length	80 bits NRZ, eight 8b/10b symbols, 64b/66b symbol			



# SPECIFICATIONS

## LabMaster 10-50Zi-A

## LabMaster 10-59Zi-A

## LabMaster 10-65Zi-A

### Triggering System

Modes	Normal, Auto, Single and Stop
Sources	Any Ch 1-4 (Edge, Window, SMART, Cascade triggers), AUX, internal Fast Edge; or any input channel (Edge trigger only) on additional 10-xxZi-A Acquisition Modules (Channels 5 and higher). Slope and level unique to each source except line trigger.
Coupling	DC, AC, HFRej, LFRej
Pre-trigger Delay	0 to 100% of memory size (adjustable in 1% increments of 100 ns)
Post-trigger Delay	0–10,000 divisions in real time mode, limited at slower time/div settings
Hold-off	From 2 ns up to 20 s or from 1 to 99,999,999 events
Trigger and Interpolator Jitter	<0.1 ps rms (typical, software assisted), 2 ps rms (typical, hardware)
Internal Trigger Level Range	±4.1 div from center
External Trigger Level Range	For any LabMaster 10xx-Zi-A Acquisition Module: Aux (±0.4 V) (Only Ch1-4 Acquisition Module has "active" AUX Input)
Maximum Trigger Rate	1,000,000 waveforms/second (in Sequence Mode, up to 4 channels)
Trigger Sensitivity with Edge Trigger (1.85/2.4/2.92mm Inputs)	For Ch 1-80 of a LabMaster 10 Zi-A system: 3 div @ < 12 GHz 1.5 div @ < 3 GHz 1.0 div @ < 200 MHz (for DC coupling, ≥ 10 mV/div, 50 Ω)
Trigger Sensitivity with Edge Trigger (Aux Input)	For Ch 1-4 LabMaster 10xx-Zi-A Acquisition Module: 2 div @ < 1 GHz, 1.5 div @ < 500 MHz, 1.0 div @ < 200 MHz, (for DC coupling)
Max. Trigger Frequency, SMART Trigger	For Ch 1-4 only of any LabMaster 10xx-Zi-A Acquisition Module: 2.0 GHz @ ≥ 10 mV/div (minimum triggerable width 200 ps)

### Trigger Types

Edge	Triggers when signal meets slope (positive, negative or either) and level condition.
Width	Triggers on positive, negative or both widths (widths selectable as low as 200 ps to 20 s) or on intermittent faults.
Glitch	Triggers on positive or negative glitches (widths selectable as low as 200 ps to 20 s) or on intermittent faults.
Window	Triggers when signal exits a window defined by adjustable thresholds.
Pattern	Logic combination (AND, NAND, OR, NOR) of 5 inputs (4 channels and external trigger input). Each source can be high, low or don't care. The high and low level can be selected independently. Triggers at start or end of the pattern.
Runt	Trigger on positive or negative runts defined by two voltage limits and two time limits. Select between 1 ns and 20 ns.
Slew Rate	Trigger on edge rates. Select limits for dV, dt and slope. Select edge limits between 1 ns and 20 ns.
Interval	Triggers on intervals selectable between 1 ns and 20 s.
Dropout	Triggers if signal drops out for longer than selected time between 1 ns and 20 s.
Exclusion Triggering	Trigger on intermittent faults by specifying the expected behavior and triggering when that condition is not met.
Measurement Trigger	Select from a large number of measurement parameters trigger on a measurement value with qualified limits. Can be used as only trigger or last event in a Cascade Trigger.
Multi-stage: Qualified	Triggers on any input source only if a defined state or edge occurred on another input source. Holdoff between sources is selectable by time or events.
Multi-stage: Qualified First	In Sequence acquisition mode, triggers repeatably on event B only if a defined pattern, state or edge (event A) is satisfied in the first segment of the acquisition. Holdoff between sources is selectable by time or events.
Multi-Stage: Cascade (Sequence) Trigger, Capability	Arm on "A" event, then Trigger on "B" event. Or Arm on "A" event, then Qualify on "B" event, and Trigger on "C" event.
Multi-Stage: Cascade (Sequence) Trigger, Types	Cascade A then B: Edge, Window, Pattern (Logic) Width, Glitch, Interval, Dropout, or Measurement. Measurement can be on Stage B only. Cascade A then B then C (Measurement): Edge, Window, Pattern (Logic), Width, Glitch, Interval, Dropout, or Measurement. Measurement can be on Stage C only. Cascade A then B then C: Edge, Window, Pattern (Logic)
Multi-Stage: Cascade (Sequence) Trigger, Holdoff	Holdoff between A and B or B and C is selectable by time or number of events. Measurement trigger selection as the last stage in a Cascade precludes a holdoff setting between the prior stage and the last stage.

### High-speed Serial Protocol Triggering (Optional)

Data Rates	Option LM10Zi-6GBIT-80B-SYMBOL-TD: 600 Mb/s to 6.5 Gb/s, Channel 4 input only Option LM10Zi-14GBIT-80B-SYMBOL-TD: 600 Mb/s to 14.1 Gb/s, Channel 4 input only (Note: Channel 3 input will capture signal for triggering when oscilloscope is in ≥ 50 GHz mode) 64b/66b triggering only available on signal rates ≥ 6.25 Gb/s
Pattern Length	80 bits NRZ, eight 8b/10b symbols, 64b/66b symbol

# SPECIFICATIONS

## LabMaster 10-20Zi-A

## LabMaster 10-25Zi-A

## LabMaster 10-30Zi-A

## LabMaster 10-36Zi-A

### Measurement Tools

Measurement Functionality	Display up to 12 measurement parameters together with statistics including mean, minimum, maximum, standard deviation, and total number. Each occurrence of each parameter is measured and added to the statistics table. Histograms provide a fast, dynamic view of parameters and waveshape characteristics. Parameter math allows addition, subtraction, multiplication or division of two different parameters. Parameter gates define the location for measurement on the source waveform. Parameter accept criteria define allowable values based on range setting or waveform state.
Measurement Parameters - Horizontal + Jitter	Cycles (number of), Cycle to Cycle, Delay (from trigger, 50%), $\Delta$ Delay (50%, @level), Edges (number of, @level), Fall Time (90-10, @levels), Frequency (50%, @level), Half Period (@level), Hold Time (@level), N Cycle Jitter (peak-peak), Number of Points, Period (50%, @level), $\Delta$ Period (@level), Phase (@level), Rise Time (10-90, @levels), Setup (@levels), Skew (@levels), Slew Rate (@levels), Time Interval Error (@level), Time (@level), $\Delta$ Time (@level), Width (50%, @level), $\Delta$ Width (@level), X(value)@max, X(value)@min
Measurement Parameters - Vertical	Amplitude, Base, Level@X, Maximum, Mean, Median, Minimum, Peak-to-Peak, RMS, Std. Deviation, Top
Measurement Parameters - Pulse	Area, Base, Fall Time (90-10, 80-20, @levels), Overshoot (positive, negative), Rise Time (10-90, 80-20, @levels), Top, Width (50%)
Measurement Parameters - Statistical (on Histograms)	Full Width (@ Half Max, @%), Amplitude, Base, Peak@MaxPopulation, Maximum, Mean, Median, Minimum, Mode, Range, RMS, Std. Deviation, Top, X(value)@Peak, Peaks (number of), Percentile, Population (@bin, total)

### Math Tools

Math Functionality	Display up to 12 math functions traces (F1-F12). The easy-to-use graphical interface simplifies setup of up to two operations on each function trace, and function traces can be chained together to perform math-on-math.
Math Operators - Basic Math	Average (summed), Average (continuous), Difference (-), Envelope, Floor, Invert (negate), Product (x), Ratio (/), Reciprocal, Rescale (with units), Roof, Sum (+)
Math Operators - Filters	Enhanced resolution (to 15 bits vertical), Interpolate (cubic, quadratic, sinx/x)
Math Operators - Frequency Analysis	FFT (power spectrum, magnitude, phase, power density, real, imaginary, magnitude squared) up to full analysis memory length. Select from Rectangular, VonHann, Hamming, FlatTop and Blackman Harris windows.
Math Operators - Functions	Absolute value, Correlation (two waveforms), Derivative, Deskew (resample), Exp (base e), Exp (base 10), Integral, Invert (negate), Log (base e), Log (base 10), Reciprocal, Rescale (with units), Square, Square root, Zoom (identity)
Math Operators - Other	Segment, Sparse

### Measurement and Math Integration

Histograms to display statistical distributions of up to 2 billion measurement parameters. Trend (datalog) of up to 1 million measurement parameters. Track (display parameter vs. time, time-correlated to acquisitions) any parameter. Persistence histogram and persistence trace (mean, range, sigma).

### Pass/Fail Testing

Display up to 12 Pass/Fail queries using a Single or Dual Parameter Comparison (compare All values, or Any value <, ≤, =, >, ≥, within limit ±Δ value or %) or Mask Test (pre-defined or user-defined mask, waveform All In, All Out, Any In, or Any Out conditions). Combine queries into a boolean expression to Pass or Fail IF "All True", "All False", "Any True", "Any False", or groups of "All" or "Any", with following THEN Save (waveforms), Stop, Alarm, (send) Pulse, Hardcopy (send email, save screen image, save to clipboard, send to printer), or (save) LabNotebook.

### Display System

Size	Color 15.3" flat panel TFT-Active Matrix LCD with high-resolution touch screen
Resolution	WXGA; 1280 x 768 pixels
Number of Traces	Display a maximum of 40 traces. Simultaneously display channel, zoom, memory and math traces.
Grid Styles	Auto, Single, Dual, Triple, Quad, Octal, X-Y, Single+X-Y, Dual+X-Y, Twelve, Sixteen. Up to twenty grids available with some software options.
Waveform Representation	Sample dots joined, or sample dots only

### Processor/CPU

Type	Intel® Xeon® Gold 6240R 24-core, 48-thread processor, 2.4 GHz per core (up to 4.0 GHz in Turbo mode) or better
Processor Memory	32 GB standard. Up to 192 GB optionally available.
Operating System	Microsoft Windows® 10
Oscilloscope Operating Software	Teledyne LeCroy MAUI™ with OneTouch
Real-Time Clock	Date and time displayed with waveform in hardcopy files. SNTP support to synchronize to precision internal clocks.

# SPECIFICATIONS

LabMaster  
10-50Zi-A

LabMaster  
10-59Zi-A

LabMaster  
10-65Zi-A

## Measurement Tools

Measurement Functionality	Display up to 12 measurement parameters together with statistics including mean, minimum, maximum, standard deviation, and total number. Each occurrence of each parameter is measured and added to the statistics table. Histograms provide a fast, dynamic view of parameters and waveshape characteristics. Parameter math allows addition, subtraction, multiplication or division of two different parameters. Parameter gates define the location for measurement on the source waveform. Parameter accept criteria define allowable values based on range setting or waveform state.
Measurement Parameters - Horizontal + Jitter	Cycles (number of), Cycle to Cycle, Delay (from trigger, 50%), $\Delta$ Delay (50%), Duty Cycle (50%, @level), Edges (number of, @level), Fall Time (90-10, @levels), Frequency (50%, @level), Half Period (@level), Hold Time (@level), N Cycle Jitter (peak-peak), Number of Points, Period (50%, @level), $\Delta$ Period (@level), Phase (@level), Rise Time (10-90, @levels), Setup (@levels), Skew (@levels), Slew Rate (@levels), Time Interval Error (@level), Time (@level), $\Delta$ Time (@level), Width (50%, @level), $\Delta$ Width (@level), X(value)@max, X(value)@min
Measurement Parameters - Vertical	Amplitude, Base, Level@X, Maximum, Mean, Median, Minimum, Peak-to-Peak, RMS, Std. Deviation, Top
Measurement Parameters - Pulse	Area, Base, Fall Time (90-10, 80-20, @levels), Overshoot (positive, negative), Rise Time (10-90, 80-20, @levels), Top, Width (50%)
Measurement Parameters - Statistical (on Histograms)	Full Width (@ Half Max, @%), Amplitude, Base, Peak@MaxPopulation, Maximum, Mean, Median, Minimum, Mode, Range, RMS, Std. Deviation, Top, X(value)@Peak, Peaks (number of), Percentile, Population (@bin, total)

## Math Tools

Math Functionality	Display up to 12 math functions traces (F1-F12). The easy-to-use graphical interface simplifies setup of up to two operations on each function trace, and function traces can be chained together to perform math-on-math.
Math Operators - Basic Math	Average (summed), Average (continuous), Difference (-), Envelope, Floor, Invert (negate), Product (x), Ratio (/), Reciprocal, Rescale (with units), Roof, Sum (+)
Math Operators - Filters	Enhanced resolution (to 15 bits vertical), Interpolate (cubic, quadratic, sinx/x)
Math Operators - Frequency Analysis	FFT (power spectrum, magnitude, phase, power density, real, imaginary, magnitude squared) up to full analysis memory length. Select from Rectangular, VonHann, Hamming, FlatTop and Blackman Harris windows.
Math Operators - Functions	Absolute value, Correlation (two waveforms), Derivative, Deskew (resample), Exp (base e), Exp (base 10), Integral, Invert (negate), Log (base e), Log (base 10), Reciprocal, Rescale (with units), Square, Square root, Zoom (identity)
Math Operators - Other	Segment, Sparse

## Measurement and Math Integration

Histograms to display statistical distributions of up to 2 billion measurement parameters. Trend (datalog) of up to 1 million measurement parameters. Track (display parameter vs. time, time-correlated to acquisitions) any parameter. Persistence histogram and persistence trace (mean, range, sigma).

## Pass/Fail Testing

Display up to 12 Pass/Fail queries using a Single or Dual Parameter Comparison (compare All values, or Any value  $<$ ,  $\leq$ ,  $=$ ,  $>$ ,  $\geq$ , within limit  $\pm\Delta$  value or %) or Mask Test (pre-defined or user-defined mask, waveform All In, All Out, Any In, or Any Out conditions). Combine queries into a boolean expression to Pass or Fail IF "All True", "All False", "Any True", "Any False", or groups of "All" or "Any", with following THEN Save (waveforms), Stop, Alarm, (send) Pulse, Hardcopy (send email, save screen image, save to clipboard, send to printer), or (save) LabNotebook.

## Display System

Size	Color 15.3" flat panel TFT-Active Matrix LCD with high-resolution touch screen
Resolution	WXGA; 1280 x 768 pixels
Number of Traces	Display a maximum of 40 traces. Simultaneously display channel, zoom, memory and math traces.
Grid Styles	Auto, Single, Dual, Triple, Quad, Octal, X-Y, Single+X-Y, Dual+X-Y, Twelve, Sixteen. Up to twenty grids available with some software options.
Waveform Representation	Sample dots joined, or sample dots only

## Processor/CPU

Type	Intel® Xeon® Gold 6240R 24-core, 48-thread processor, 2.4 GHz per core (up to 4.0 GHz in Turbo mode) or better
Processor Memory	32 GB standard. Up to 192 GB optionally available.
Operating System	Microsoft Windows® 10
Oscilloscope Operating Software	Teledyne LeCroy MAUI™ with OneTouch
Real-Time Clock	Date and time displayed with waveform in hardcopy files. SNTP support to synchronize to precision internal clocks.

# SPECIFICATIONS

	LabMaster 10-20Zi-A	LabMaster 10-25Zi-A	LabMaster 10-30Zi-A	LabMaster 10-36Zi-A
<b>Connectivity</b>				
Ethernet Port	Supports 10/100/1000BaseT Ethernet interface (RJ45 port)			
USB Host Ports	LabMaster MCM-Zi -A Master Control Module: 1 x USB 2.0 ports, 1 x USB Type-C and 4 x USB3.1 Gen1 on rear of unit to support Windows compatible devices LabMaster MCM-Zi -A Master Control Module: minimum 3 total USB 2.0 ports on front of unit to support Windows compatible devices			
GPIB Port (Optional)	Supports IEEE-488.2			
External Monitor Port	Dual Link DVI compatible to support internal display on MCM-Zi Master Control Module (1280 x 768 pixel resolution) and customer-supplied monitor with up to WQXGA (2560 x 1600 pixel) resolution using extended desktop mode.			
Remote Control	Via Windows Automation, or via LeCroy Remote Command Set			
Network Communication Standard	VXI-11 or VICP, LXI Class C (v1.2) compliant			
<b>Power Requirements</b>				
Voltage	LabMaster 10-xxZi Acquisition Module: 100–240 VAC ±10% at 45-66 Hz; 100-120 VAC ±10% at 380-420 Hz; Automatic AC Voltage Selection, Installation Category II LabMaster MCM-Zi Master Control Module: 100–240 VAC ±10% at 45-66 Hz; Automatic AC Voltage Selection, Installation Category II			
Max Power Consumption	LabMaster 10-xxZi-A Acquisition Module - 1225 W / 1225 VA. LabMaster MCM-Zi-A Master Control Module - 450 W / 450 VA. Each Module and the CPU has a separate power cord.			
<b>Environmental</b>				
Temperature (Operating)	+5 °C to +40 °C			
Temperature (Non-Operating)	–20 °C to +60 °C			
Humidity (Operating)	5% to 80% RH (non-condensing) up to +31 °C, upper limit derating to 50% RH (non-condensing) at +40 °C			
Humidity (Non-Operating)	5% to 95% RH (non-condensing) as tested per MIL-PRF-28800F			
Altitude (Operating)	Up to 10,000 ft (3048 m) at or below +25 °C			
Altitude (Non-Operating)	Up to 40,000 ft (12,192 m)			
Random Vibration (Operating)	0.5 grms 5 Hz to 500 Hz, 15 minutes in each of three orthogonal axes			
Random Vibration (Non-Operating)	2.4 grms 5 Hz to 500 Hz, 15 minutes in each of three orthogonal axes			
Functional Shock	20 g peak, half sine, 11 ms pulse, 3 shocks (positive and negative) in each of three orthogonal axes, 18 shocks total			
<b>Size and Weight</b>				
Dimensions (HWD)	LabMaster MCM-Zi-A Master Control Module - 10.9"H x 18.2"W x 15.6"D (277 x 462 x 396 mm), LabMaster 10-xxZi-A Acquisition Module - 8.0"H x 18.2"W x 26"D (202 x 462 x 660 mm)			
Weight	LabMaster MCM-Zi-A Master Control Module - 47 lbs. (21.4 kg), LabMaster 10-xxZi-A Acquisition Module -53 lbs. (24.1 kg)			
Shipping Weight	LabMaster MCM-Zi-A Master Control Module - 56 lbs. (25.5 kg) LabMaster 10-xxZi-A Acquisition Module -71 lbs. (32.3 kg)			
<b>Certifications</b>				
CE Certification UL and cUL Listing	CE compliant, UL and cUL listed; conforms to EN 61326, EN 61010-1, EN61010-2-030, UL 61010-1 3rd edition and CSA C22.2 No. 61010-1-12			
<b>Warranty and Service</b>				
	3-year warranty; calibration recommended annually. Optional service programs include extended warranty, upgrades and calibration services.			



# SPECIFICATIONS

## LabMaster 10-50Zi-A

## LabMaster 10-59Zi-A

## LabMaster 10-65Zi-A

### Connectivity

Ethernet Port	Supports 10/100/1000BaseT Ethernet interface (RJ45 port)
USB Host Ports	LabMaster MCM-Zi -A Master Control Module: 1 x USB 2.0 ports, 1 x USB Type-C and 4 x USB3.1 Gen1 on rear of unit to support Windows compatible devices LabMaster MCM-Zi -A Master Control Module: minimum 3 total USB 2.0 ports on front of unit to support Windows compatible devices
GPIO Port (Optional)	Supports IEEE-488.2
External Monitor Port	Dual Link DVI compatible to support internal display on MCM-Zi Master Control Module (1280 x 768 pixel resolution) and customer-supplied monitor with up to WQXGA (2560 x 1600 pixel) resolution using extended desktop mode.
Remote Control	Via Windows Automation, or via LeCroy Remote Command Set
Network Communication Standard	VXI-11 or VICP, LXI Class C (v1.2) compliant

### Power Requirements

Voltage	LabMaster 10-xxZi Acquisition Module: 100–240 VAC ±10% at 45-66 Hz; 100-120 VAC ±10% at 380-420 Hz; Automatic AC Voltage Selection, Installation Category II LabMaster MCM-Zi Master Control Module: 100–240 VAC ±10% at 45-66 Hz; Automatic AC Voltage Selection, Installation Category II
Max Power Consumption	LabMaster 10-xxZi-A Acquisition Module - 1275 W / 1275 VA. LabMaster MCM-Zi-A Master Control Module - 450 W / 450 VA. Each Module and the CPU has a separate power cord.

### Environmental

Temperature (Operating)	+5 °C to +40 °C
Temperature (Non-Operating)	-20 °C to +60 °C
Humidity (Operating)	5% to 80% RH (non-condensing) up to +31 °C, upper limit derating to 50% RH (non-condensing) at +40 °C
Humidity (Non-Operating)	5% to 95% RH (non-condensing) as tested per MIL-PRF-28800F
Altitude (Operating)	Up to 10,000 ft (3048 m) at or below +25 °C
Altitude (Non-Operating)	Up to 40,000 ft (12,192 m)
Random Vibration (Operating)	0.5 grms 5 Hz to 500 Hz, 15 minutes in each of three orthogonal axes
Random Vibration (Non-Operating)	2.4 grms 5 Hz to 500 Hz, 15 minutes in each of three orthogonal axes
Functional Shock	20 g peak, half sine, 11 ms pulse, 3 shocks (positive and negative) in each of three orthogonal axes, 18 shocks total

### Size and Weight

Dimensions (HWD)	LabMaster MCM-Zi-A Master Control Module - 10.9"H x 18.2"W x 15.6"D (277 x 462 x 396 mm), LabMaster 10-xxZi-A Acquisition Module - 8.0"H x 18.2"W x 26"D (202 x 462 x 660 mm)
Weight	LabMaster MCM-Zi-A Master Control Module - 47 lbs. (21.4 kg) LabMaster 10-xxZi-A Acquisition Module -58 lbs. (24.1 kg)
Shipping Weight	LabMaster MCM-Zi-A Master Control Module - 56 lbs. (25.5 kg) LabMaster 10-xxZi-A Acquisition Module -76 lbs. (34.5 kg)

### Certifications

CE Certification UL and cUL Listing	CE compliant, UL and cUL listed; conforms to EN 61326, EN 61010-1, EN61010-2-030, UL 61010-1 3rd edition and CSA C22.2 No. 61010-1-12
--	---

### Warranty and Service

3-year warranty; calibration recommended annually. Optional service programs include extended warranty, upgrades and calibration services.

# ORDERING INFORMATION

## Product Description

## Product Code

### LabMaster 10 Zi-A Series Master Control Modules

LabMaster Master Control Module with 15.3" WXGA Color Display.	LabMaster MCM-Zi-A
SDA Master Control Module with 15.3" WXGA Color Display (provides add'l standard software and 64 Mpt/Ch memory)	SDA MCM-Zi-A

### LabMaster 10 Zi-A Series Acquisition Modules

20 GHz, 80 GS/s, 4 Ch, 32 Mpts/Ch LabMaster 10 Zi Acquisition Module with 50 Ω input	LabMaster 10-20Zi-A
25 GHz, 80 GS/s, 4 Ch, 32 Mpts/Ch LabMaster 10 Zi Acquisition Module with 50 Ω input	LabMaster 10-25Zi-A
30 GHz, 80 GS/s, 4 Ch, 32 Mpts/Ch LabMaster 10 Zi Acquisition Module with 50 Ω input	LabMaster 10-30Zi-A
36 GHz, 80 GS/s, 4 Ch, 32 Mpts/Ch LabMaster 10 Zi Acquisition Module with 50 Ω input	LabMaster 10-36Zi-A
50 GHz, 160 GS/s, 2 Ch, 64 Mpts/Ch LabMaster 10 Zi Acquisition Module with 50 Ω input	LabMaster 10-50Zi-A
(36 GHz, 80 GS/s, 4 Ch, 32 Mpts/Ch)	
59 GHz, 160 GS/s, 2 Ch, 64 Mpts/Ch LabMaster 10 Zi Acquisition Module with 50 Ω input	LabMaster 10-59Zi-A
(36 GHz, 80 GS/s, 4 Ch, 32 Mpts/Ch)	
65 GHz, 160 GS/s, 2 Ch, 64 Mpts/Ch LabMaster 10 Zi Acquisition Module with 50 Ω input	LabMaster 10-65Zi-A
(36 GHz, 80 GS/s, 4 Ch, 32 Mpts/Ch)	

### Included with LabMaster MCM-Zi-A Standard Configuration

Power Cable for the Destination Country, Optical 3-button Wheel Mouse USB 2.0, Printed Getting Started Manual, Anti-virus Software (Trial Version), Microsoft Windows 7 License, Commercial NIST Traceable Calibration with Certificate, 3-year Warranty

### Included with LabMaster 10-xxZi-A Standard Configuration

2.92mm Connector Saver: Qty. 4, 1.85mm Barrel Adapter: Qty. 2 (50-65 GHz units only), PCIe x 8 cable, 2m long, PCIe x 4 cable, 2m long, Power Cable for the Destination Country, ChannelSync 10 GHz clock cable, 2m long, Commercial NIST Traceable Calibration with Certificate, 3-year Warranty

### ChannelSync Expansion Products

ChannelSync Mainframe Hub to permit LabMaster expansion to up to 20 acquisition modules	LabMaster CMH20-Zi
Expansion ChannelSync module card for ChannelSync Mainframe Hub. One required per connected acquisition module	LabMaster CMH-1ACQMODULE-Zi

### Memory Options

64 Mpts/Ch Memory Option for LabMaster 10 Zi Acquisition Modules	LM10Zi-M-64
128 Mpts/Ch Memory Option for LabMaster 10 Zi Acquisition Modules	LM10Zi-L-128
128 Mpts/Ch Memory Option for LabMaster 10 Zi Acquisition Modules. Used with SDA MCM-Zi-A	SDA10Zi-L-128
256 Mpts/Ch Memory Option for LabMaster 10 Zi Acquisition Modules	LM10Zi-VL-256
512 Mpts/Ch Memory Option for LabMaster 10 Zi Acquisition Modules	LM10Zi-XL-512
512 Mpts/Ch Memory Option for LabMaster 10 Zi Acquisition Modules. Used with SDA MCM-Zi-A	SDA10Zi-XL-512

## Product Description

## Product Code

### CPU, Computer and Other Hardware Options for LabMaster MCM-Zi-A Master Control Module

Additional 500 GB Hard Drive for MCM-Zi-A	MCMZi-500GB-RHD-02
Upgrade to 128 GB RAM for MCM-Zi-A	MCMZi-32-UPG-128GB
Upgrade to 192 GB RAM for MCM-Zi-A	MCMZi-32-UPG-192GB
GPIO Option for LabMaster MCM-Zi-A	GPIO-3

### High-speed Digital Analyzer Systems

12.5 GS/s High-speed Digital Analyzer with 18ch QuickLink leadset and SYNC connection	HDA125-18-SYNC
12.5 GS/s High-speed Digital Analyzer with 9ch QuickLink leadset and SYNC connection	HDA125-09-SYNC
18 channel QuickLink leadset for HDA125	HDA-DLS-18QL
9 channel QuickLink leadset for HDA125	HDA-DLS-09QL

### Ethernet and DDR Debug Toolkits

100Base-T1 and 1000Base-T1 Debug Toolkit	LM10Zi-AUTO-ENET-TOOLKIT
DDR 2/3/4/5 and LPDDR 2/3/4/4X Debug Toolkit	LM10Zi-DDR5-TOOLKIT
DDR 2/3/4 and LPDDR 2/3/4/4X Debug Toolkit	LM10Zi-DDR4-TOOLKIT
DDR 2/3 and LPDDR 2/3 Debug Toolkit	LM10Zi-DDR3-TOOLKIT
DDR2 and LPDDR2 Debug Toolkit	LM10Zi-DDR2-TOOLKIT

### Serial Data and Crosstalk Analysis

SDA Expert single lane eye, noise and jitter analysis for NRZ signals	LM10Zi-SDAX-NRZ
SDA Expert single lane eye, noise and jitter analysis for PAM3 and PAM4 signals	LM10Zi-SDAX-PAM
SDA Expert multilane eye, noise and jitter analysis for NRZ, PAM3, PAM4 signals. Includes integrated EyeDrII and VirtualProbe toolkits	LM10Zi-SDAX-COMPLETE
SDA Expert configuration and measurements for NRZ PCI Express signals up to 32 GT/s	LM10Zi-SDAX-PCIE-NRZ
SDA Expert configuration and measurements for USB3.2 signals at 5 Gb/s and 10 Gb/s	LM10Zi-SDAX-USB32
SDA Expert configuration and measurements for USB4 NRZ signals at 10 Gb/s and 20 Gb/s, and PAM3 signals at 40 Gb/s	LM10Zi-SDAX-USB4-TBT
SDA Expert Technology Framework for PCIe 6 Single-Lane Serial Data Analysis Framework, Eye and Jitter Measurements	LM10Zi-SDAX-PCIE6 LM10Zi-SDAIII
Bundle - Multi-Lane SDA LinQ Framework, including Eye, Jitter, Noise, Crosstalk Measurements, with EyeDrII and VirtualProbe	LM10Zi-SDAIII-CompleteLinQ SDA10Zi-CompleteLinQ DDA10Zi-CompleteLinQ
PCIe 6.0 Transmitter Measurements	LM10Zi-SDAIII-PCIE6
PAMx Serial Data Analysis, Eye, Jitter and Noise Measurements	LM10Zi-SDAIII-PAMx

### Signal Integrity Toolkits

Advanced De-embedding, Emulation and Virtual Probing Toolkit	LM10Zi-VIRTUALPROBE
Signal Integrity Toolkit - Channel & Fixture De-embedding/Emulation, Tx/Rx Equalization	LM10Zi-EYEDRII
Bundle - EyeDrII and VirtualProbe Toolkits	LM10Zi-EYEDRII-VP
Cable De-embed Option	LM10Zi-CBL-DE-EMBED

### Modulated Signal Analysis

VectorLinQ Advanced Vector Signal Analysis including OFDM	LM10Zi-VECTORLINQ-ADV
VectorLinQ - Flexible Vector Signal Analysis for electrical signals (RF and baseband I-Q)	LM10Zi-VECTORLINQ

# ORDERING INFORMATION

## Product Description

## Product Code

### CrossSync™ PHY Software

CrossSync PHY protocol analyzer synchronization Option for PCIe	LM10ZI-CROSSSYNC-PHY-PCIe
CrossSync PHY protocol analyzer synchronization Option for USB and Thunderbolt	LM10ZI-CROSSSYNC-PHY-USB

### Serial Data Compliance

QualiPHY Enabled MultiGBase-T1 (Automotive Ethernet) Compliance Software Option	QPHY-MultiGBase-T1
QualiPHY Enabled 10Base-T1L (Industrial Ethernet) Compliance Software Option	QPHY-10Base-T1L
QualiPHY Enabled 10Base-T1S (Automotive Ethernet) Compliance Software Option	QPHY-10Base-T1S
QualiPHY Enabled 10GBase-KR Software Option	QPHY-10GBase-KR
QualiPHY Enabled 10GBase-T Software Option.	QPHY-10GBase-T
QualiPHY Enabled 56G PAM4 Compliance Software Option	QPHY-56G-PAM4
QualiPHY Enabled LPDDR2 Software Option	QPHY-LPDDR2
QualiPHY Enabled DDR3, DDR3L and LPDDR3 Software Option	QPHY-DDR3
QualiPHY Enabled DDR4 and LPDDR4/4X Software Option	QPHY-DDR4
QualiPHY DDR5 System Level Software Option	QPHY-DDR5-SYS
DDR5 Bundle Enabled QualiPHY + Debug Toolkit Options for all DDR2/3/4/5 and LPDDR2/3/4/4X	LM10ZI-DDR5-BUNDLE
QualiPHY Enabled DisplayPort 2.0 Source Software Option (Includes DP 1.4 Source)	QPHY-DP20-Source
QualiPHY Enabled DisplayPort 1.4 Source Software Option	QPHY-DP14-Source
QualiPHY Enabled DisplayPort 2.0 Sink Software Option	QPHY-DP20-Sink
QualiPHY Enabled Embedded DisplayPort Software Option	QPHY-eDP
QualiPHY Enabled HDMI 2.1 FRL and TMDS Software Option (Includes HDMI 1.4 and HDMI 2.0)	QPHY-HDMI21
QualiPHY Enabled HDMI 2.0/1.4 FRL TMDS Software Option	QPHY-HDMI2
QualiPHY Enabled MIPI C-PHY Compliance Software Option (includes C-PHY DMP)	QPHY-MIPI-CPHY
QualiPHY Enabled MIPI M-PHY Compliance Software Option	QPHY-MIPI-MPHY
QualiPHY Enabled PCIe 3.0 Transmitter/Receiver Compliance Software Option	QPHY-PCIE3-Tx-Rx
QualiPHY Enabled PCIe 4.0 Transmitter/Receiver Compliance Software Option	QPHY-PCIE4-Tx-Rx
QualiPHY Enabled PCIe 5.0 Transmitter/Receiver Compliance Software Option	QPHY-PCIE5-TX-RX
QualiPHY Enabled PCIe 6.0 Transmitter/Receiver Compliance Software Option	QPHY-PCIE6-TX-RX
QualiPHY Enabled PCIe Gen1 Software Option	QPHY-PCIe
QualiPHY Enabled SATA Software Option	QPHY-SATA-TSG-RSG
QualiPHY Enabled SAS-2 Software Option	QPHY-SAS2
QualiPHY Enabled SAS3 Software Option	QPHY-SAS3
QualiPHY Enabled SFI Software Option	QPHY-SFI
QualiPHY Enabled USB4 Tx and Rx Software Option	QPHY-USB4-Tx-Rx
QualiPHY Enabled USB 3.2 Tx and Rx Software Option	QPHY-USB3.2-Tx-Rx

PCI Express, SuperSpeed USB (USB 3.0) and SATA Complete Hardware/Software Test Solutions are available. Consult Factory.

### Serial Data Test Fixtures

USB4 Sideband Test Coupon Fixture (USB Type-C)	TF-USB-C-SB
USB4 High-speed and Sideband Test Coupon Fixture (USB Type-C)	TF-USB-C-HS
HDMI Pull-Up Terminator Quad Pack	TF-HDMI-3.3V-QUADPAK
USB 3.1 (Standard Type A/B Connector) Test Fixtures	TF-USB3
SATA 1.5 Gb/s, 3.0 Gb/s and 6.0 Gb/s Compliance Test Fixture Measure Kit	TF-SATA-C-KIT
Test Fixture for 10GBase-T	TF-10GBASE-T
Automotive Ethernet Breakout Test Fixture for 100Base-T1 and 1000Base-T1 Debug	TF-AUTO-ENET
4 pack of SMA Connector boards for TF-AUTO-ENET	TF-AUTO-ENET-SMA
MIPI M-PHY input offset adapter dual pack	TF-MIPI-MPHY-DUALPAK

## Product Description

## Product Code

### Serial Data Triggers and Decoders

600 Mb/s to 14.1 Gb/s 80-bit NRZ, 8b/10b and 64b/66b Serial Trigger. Also includes 8b/10b and 64b/66b Decode.	LM10ZI-14GBIT-80B-SYMBOL-TD
600 Mb/s to 6.5 Gb/s 80-bit NRZ, 8b/10b, 64b/66b Serial Trigger. Also includes 8b/10b and 64b/66b Decode.	LM10ZI-6GBIT-80B-SYMBOL-TD
64b/66b Decode Annotation Option	LM10ZI-64b66b D
8b/10b Decode Annotation Option	LM10ZI-8B10B D
CAN FD Decode Option	LM10ZI-CAN FDbus D
ENET Decode Option	LM10ZI-ENETbus D
Ethernet 10G Decode Option	LM10ZI-ENET10Gbus D
PCI Express 5.0 to 1.0 Link Layer Decode Option	LM10ZI-PCIEbus D
PCI Express 6.0 to 1.0 Link Layer Decode Option	LM10ZI-PCIE6BUS D
USB4bus Decode, Measure/Graph, and Eye Measurements Option	LM10ZI-USB4bus DME
USB4-SB Decode, Measure/Graph, and PHY Measurement Option	LM10ZI-USB4SB DMP
USB4-SB Decode Option	LM10ZI-USB4SB D
USB 3.2 bus D Option (Includes USB2 bus D)	LM10ZI-USB 3.2 bus D
USB-PD (Power Delivery) Decode, Measure/Graph, and Physical Layer Option	LM10ZI-USBPD DMP
USB-PD Decode Option	LM10ZI-USBPD D
DP-AUX AUX Decode, Measure/Graph, and Physical Layer (Supports all DisplayPort connector types)	LM10ZI-DPAUX DMP
DisplayPort AUX Decode Option	LM10ZI-DPAUX D
USB2-HSIC Decode Option	LM10ZI-USB2-HSICbus D
SATA Decode Annotation Option	LM10ZI-SATAbus D
SAS Decode Annotation Option	LM10ZI-SASbus D
Fibre Channel Decode Annotation Option	LM10ZI-FCbus D
D-PHY Decode Option	LM10ZI-DPHYbus D
DigRF 3G Decode Option	LM10ZI-DigRF3Gbus D
DigRF v4 Decode Option	LM10ZI-DIGRFv4bus D
Audibus and Decode Option for I <sup>2</sup> S, LJ, RJ, and TDM	LM10ZI-Audibus D
Audibus, Decode, and Graph Option for I <sup>2</sup> S, LJ, RJ, and TDM	LM10ZI-Audibus DG
Manchester Decode Option	LM10ZI-Manchesterbus D
MDIO Decode Option	LM10ZI-MDIObus D
C-PHY (DSI-2/CSI-2) Decode Option	LM10ZI-CPHYBUS D
C-PHY (DSI-2/CSI-2) Decode, Measure/Graph and Physical Layer Option	LM10ZI-CPHYBUS DMP
MIPI D-PHY Decode Annotation Option	LM10ZI-DPHYbus D
MIPI D-PHY Decode and Physical Layer Test Option	LM10ZI-DPHYbus DP
MIPI M-PHY Decode Annotation Option	LM10ZI-MPHYbus D
MIPI M-PHY Decode Annotation and Physical Layer Test Option	LM10ZI-MPHYbus DP
MIPI UniPro Protocol Decode Option	LM10ZI-UNIPRObus D
SpaceWire Decode Option	LM10ZI-SpaceWirebus D
I <sup>2</sup> C Bus and Decode Option	LM10ZI-I2Cbus D
I <sup>3</sup> C Decode, Measure/Graph, and Eye Diagram Option	LM10ZI-I3CBUS DME
I <sup>3</sup> C Decode Option	LM10ZI-I3CBUS D
SPI Bus and Decode Option	LM10ZI-SPIbus D
SPMI Decode Option	LM10ZI-SPMIbus D
LIN and Decode Option	LM10ZI-LINbus D
UART and RS-232 and Decode Option	LM10ZI-UART-RS232bus D
FlexRay and Decode Option	LM10ZI-FlexRaybus D
FlexRay, Decode, and Physical Layer Test Option	LM10ZI-FlexRaybus DP
MIL-STD-1553 Decode Option	LM10ZI-1553 D
ARINC 429 Symbolic Decode Option	LM10ZI-ARINC429bus DSymbolic
Decode Annotation and Protocol Analyzer Synchronization Software Option	LM10ZI-ProtoSync
Decode Annotation and Protocol Analyzer Synchronization Software + Bit Tracer Option	LM10ZI-ProtoSync-BT
SENT Decode Option	LM10ZI-SENTbus D

# ORDERING INFORMATION

## Product Description

## Product Code

### General Purpose and Application Specific Software Options

Spectrum Analyzer for LabMaster 10 Zi - 1 trace	LM10Zi-SPECTRUM-1
Spectrum Analyzer for LabMaster 10 Zi - 2 traces + reference	LM10Zi-SPECTRUM-PRO-2R
MAUI Studio Pro Offline Remote and PC Analysis Software License	MAUI Studio Pro
Digital Filter Software Package	LM10Zi-DFP2
Serial Data Mask Software Package	LM10Zi-SDM
Disk Drive Measurements Software Package	LM10Zi-DDM2
Disk Drive Analyzer Software Package	LM10Zi-DDA
Advanced Optical Recording Measurement Package	LM10Zi-AORM
EMC Pulse Parameter Software Package	LM10Zi-EMC
Clock Jitter Analysis with Four Views Software Package	LM10Zi-JITKIT

### Miscellaneous

MCM-Zi-A Rackmount Kit	MCM-Zi-RACKMOUNT
LabMaster 10 Zi-A Acquisition Module Rackmount Kit	LM10Zi-ACQMOD-RACKMOUNT

## Product Description

## Product Code

### Probes and Probe Accessories

25 GHz differential probe with 2.92mm interface	DH25-2.92MM
30 GHz differential probe with 2.92mm interface	DH30-2.92MM
DH series high-sensitivity solder-in tip, 30 GHz BW, 2.0 Vpp range	DH-SI-HS
DH series solder-in tip, 30 GHz BW, 3.5 Vpp range	DH-SI
DH series high-temperature solder-in tip, 16 GHz BW, 3.5 Vpp range	DH-HITEMP
DH series QuickLink adapter, 8 GHz BW	DH-QL
DH series QuickLink adapter kit with 3 x QL-SI tips	DH-QL-3SI
DH series PT browser tip, 16 GHz BW, 3.5 Vpp range	DH-PT
250 MHz 60 V Common Mode Differential Probe	DL02-HCM
500 MHz 60 V Common Mode Differential Probe	DL05-HCM
1 GHz 60 V Common Mode Differential Probe	DL10-HCM
WaveLink 13 GHz, 2.0 Vp-p Differential Probe System	D1305-A-PS
WaveLink 16 GHz, 2.0 Vp-p Differential Probe System	D1605-A-PS
WaveLink 20 GHz, 2.0 Vp-p Differential Probe System	D2005-A-PS
WaveLink 25 GHz, 2.0 Vp-p Differential Probe System	D2505-A-PS
Power/Voltage Rail Probe 2 GHz, 1.2x, ±60V offset, ±800mV dynamic range	RP2060
Power/Voltage Rail Probe 4 GHz, 1.2x, ±30V offset, ±800mV dynamic range	RP4060
RP2060/RP4060 Browser Tip accessory. Includes 0 Ohm (1x), 450 Ohm (10x) and 950 Ohm (20x) tips.	RP4000-BROWSER
Qty 3 MCX 4 GHz solder-in lead accessories (additional to those supplied with rail probe) 18cm long	RP4000-MCX-LEAD-SI
2.92mm to ProLink Adapter with probe power and communications pass through	L2.92A-PLINK
2.92mm to ProBus Adapter with probe power and communications pass through	L2.92A-PBUS

## Customer Service

Teledyne LeCroy oscilloscopes and probes are designed, built and tested to ensure high reliability. In the unlikely event you experience difficulties, our digital oscilloscopes are fully warranted for three years and our probes are warranted for one year. This warranty includes:

- No charge for return shipping
- Long-term 7-year support
- Upgrade to latest software at no charge



1-800-5-LeCroy  
teledyneleeroy.com

Local sales offices are located throughout the world.  
Visit our website to find the most convenient location.

© 2024 by Teledyne LeCroy, Inc. All rights reserved. Specifications, prices, availability, and delivery subject to change without notice.

PCI Express® is a registered trademark and/or service mark of PCI-SIG.

USB4® and USB Type-C® are registered trademarks and/or service marks of USB-IF. MATLAB® is a registered trademark of The MathWorks, Inc. All other product or brand names are trademarks or requested trademarks of their respective holders.

labmaster10zi-a-ds-25jan24